

WHITE PAPER

A BRAVE NEW WORLD IS DAWNING, AND LITH TOKEN WILL BE THE FUEL THAT POWERS IT. DECENTRALIZING A CLEANER FUTURE THROUGH CRYPTOCURRENCY.

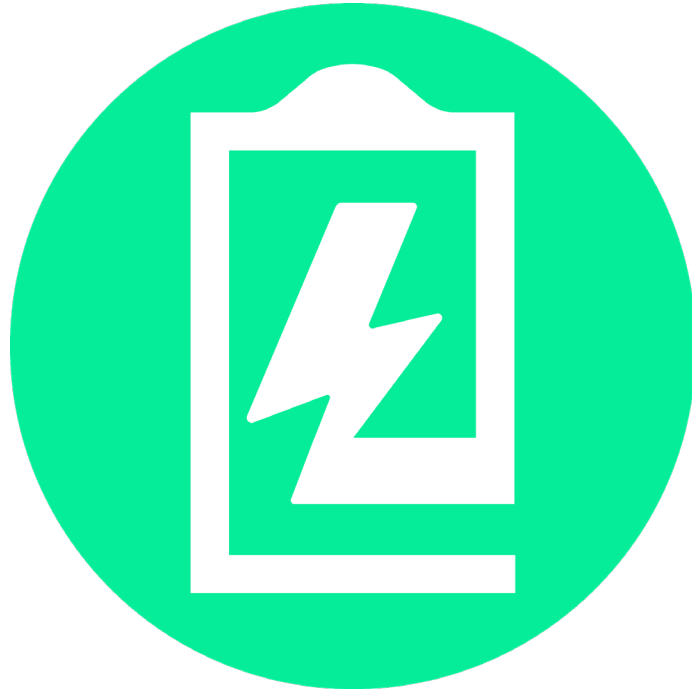

LITH TOKEN

VISIT [LITHTOKEN.IO](https://lithtoken.io)

CONTENTS

INTRODUCTION

- 1.1 OUR MISSION
- 1.2 WHO WE ARE
- 1.3 BLOCKCHAIN MEETS ESG
- 1.4 BUSINESS & CONSUMER REWARDS
- 1.5 ORGANIZATION LICENSING
- 1.6 EVER INCREASING ESG DEMAND
- 1.7 EGS SUPPLY CHAIN AUTHENTICATION
- 1.8 ESG CONSUMERS & BUSINESSES
- 1.9 **LITH** WALLET

ESG

- 2.1 WHAT IS ESG?
- 2.2 ESG IMPLEMENTATION
- 2.3 GENERAL ESG CRITERIA
- 2.4 ESG SURVEYS & RANKINGS
- 2.5 ESG REVIEW SYSTEM
- 2.6 **SHOPLITH**
 - 2.6.1 PHYSICAL NFT'S + ESG DATA
- 2.7 **LITH** ESG API

BLOCKCHAIN

3.1 WHY ERC-1155?

3.1.1 SMART CONTRACTS

3.1.2 DECENTRALIZATION

3.1.3 FUNGIBLE & NON-FUNGIBLE

3.1.4 SECURITY/ENCRYPTION

3.1.5 PEER-TO-PEER TRANSACTIONS

3.1.6 SUPPLY CHAIN TRANSPARENCY

3.2 BLOCKCHAIN HUB

3.3 NOANE PROTOCOL

3.3.1 GENERATING AND MAINTAINING DIGITAL TOKENS ON A BLOCKCHAIN USING PHYSICAL IDENTIFIERS

LITH TOKENOMICS

4.1 ETHEREUM

4.2 TOKENOMICS

4.3 **LITH TOKEN**

4.4 ERC-1155

4.5 UNISWAP

4.6 WHY **LITH TOKEN**

4.7 TOKEN CHARACTERISTICS

4.7.1 LITH (ERC-20) TECHNICAL SYSTEM OVERVIEW

4.8 BLOCKCHAIN BRIDGES

4.9.0 PROXY CONTRACTS

4.9.1 MARKETPLACE ECOSYSTEM

4.9.2 CARBON CREDIT NFT'S

PROJECT DEVELOPMENT

5.1 STRATEGIC PARTNERSHIPS

5.2 THE ROAD MAP

PHASE 1 - EARLY-STAGE PREPARATION

PHASE 2 - TOKEN LAUNCH

PHASE 3 - TOKEN LAUNCH 2.0

PHASE 4 - MARKETPLACE & BLOCKCHAIN HUB

PHASE 5 - **LITH** ESG API

PHASE 6 - CEMENTING THE FULL **LITH** ECOSYSTEM

LITH GROUP

6.1 TOKEN ISSUING TEAM

6.2 DEVELOPMENT TEAM

6.3 MARKETPLACE & MANAGEMENT TEAM

6.4 PRESS & MARKETING TEAM

6.5 DISCLAIMER

TOKEN INFO

TOKEN NAME: LITH TOKEN

TICKER SYMBOL: LITH

TOKEN CONTRACT (ERC20): **0XF8A4A419C2D7140E49EF952A7E7AE1BD4A8B6B92**

BSC BRIDGED TOKEN CONTRACT: **0x747d9ba770d2fb035bc2350ea3c637fd10d6607f**

MINIMUM REQUIREMENTS FOR LITx:

ERC-20 STANDARD: <https://ethereum.org/en/developers/docs/standards/tokens/erc-20/>

UNISWAP PROTOCOL: <https://docs.uniswap.org/protocol/V2/introduction>

UNISWAP INTEGRATION: <https://docs.uniswap.org/protocol/V2/guides/smart-contract-integration/quick-start>

POST MIGRATION ECOSYSTEM:

V2 ERC-20 TICKER SYMBOL: LITx

ERC-1155 CONTRACT NAME: LITHplus

GITHUB: <https://github.com/LITHToken>

INTRODUCTION

1.1 OUR MISSION

THE **LITH TOKEN** (ERC-20 & ERC-1155) WILL BE THE CRYPTOCURRENCY OF CHOICE FOR SUSTAINABLE AND SOCIALLY CONSCIOUS BUSINESSES TO THRIVE. **LITH** UTILIZES BLOCKCHAIN TECHNOLOGY TO CREATE AN ENVIRONMENT WHERE ALL INDIVIDUALS AND ORGANIZATIONS WITHIN AN ECOSYSTEM ARE INCENTIVIZED TO WORK TOGETHER TOWARD A COMMON GOAL: CREATING A BETTER WORLD THROUGH DECENTRALIZATION AND ACCOUNTABILITY IN BUSINESS.

WE'LL SEE A COMPLETE TRANSFORMATION OF OUR WORLD AS BLOCKCHAIN TECHNOLOGY AND CRYPTOCURRENCIES COME TO DOMINATE EVERY ASPECT OF OUR LIVES.

1.2 WHO WE ARE

LITH IS A DIVERSE TEAM OF EXPERTS WITH EXPERIENCE IN VARIOUS FIELDS INCLUDING TECHNOLOGY, BUSINESS, FINANCE AND LAW. OUR GOAL IS TO CREATE OPPORTUNITIES FOR INDIVIDUALS AND BUSINESSES THAT HAVE THE POTENTIAL TO SCALE ON AN INTERNATIONAL LEVEL WHILE REMAINING SOCIALLY AND ENVIRONMENTALLY CONSCIOUS. AS MORE COUNTRIES ACROSS THE GLOBE ARE ADOPTING ENVIRONMENTAL SOCIAL GOVERNANCE MODELS (ESG), **LITH** MERCHANTS WILL BE ABLE TO ACCESS ONE GLOBAL DECENTRALIZED NETWORK WHICH WILL PROVIDE THEM WITH NEW POSSIBILITIES - A MARKET OF ENDLESS OPPORTUNITY STRETCHING BEFORE US EVERY DAY AS WE GROW TOGETHER!

1.3 BLOCKCHAIN MEETS ESG

LITH WILL REVOLUTIONIZE THE MODEL FOR ENVIRONMENTAL AND SOCIAL GOVERNANCE. BY CREATING A PLATFORM TO MEET GROWING DEMAND FOR INTEGRITY IN COMMERCE. **LITH** UNITES ALL ASPECTS OF PRODUCTION: FINANCE, RESOURCE GATHERING, MANUFACTURING AND DISTRIBUTING BY INTEGRATING BLOCKCHAIN ACCOUNTABILITY. ADDITIONALLY, BY INTRODUCING TOKENS THAT CARRY INHERENT VALUE ON THE MARKET - THIS MOVEMENT COULD POTENTIALLY CHANGE HOW PEOPLE INTERACT WITH THEIR MONEY ALTOGETHER! IT CAN BE SETUP IN TWO YEARS THANKS TO LARGE SOFTWARE DEVELOPMENT NEEDED AS WELL AS SERVER ENGINEERING THAT MUST FIRST BE FINANCED, DEVELOPED AND IMPLEMENTED.

1.4 BUSINESS & CONSUMER REWARDS

THE GOAL OF **LITH**'S ENVIRONMENTAL SOCIAL GOVERNANCE MODEL IS TO MOVE HUMANITY BEYOND THE 21ST CENTURY BY UNLEASHING A CYCLICAL REWARD-BASED SYSTEM. CONSUMERS AND BUSINESSES RELY ON INCENTIVES, WHICH ARE INCREASING RAPIDLY BECAUSE OF THE DEMAND FOR ETHICAL BUSINESS PRACTICES. THAT'S WHY IT HAS PROVEN BEST FOR THIS NICHE MARKET IF WE USE REWARDS SYSTEMS THAT ENCOURAGE BOTH CONSUMERS AND COMPANIES TOWARDS ENVIRONMENTALLY RESPONSIBLE BEHAVIOR. THE **LITH** PLATFORMS WILL UTILIZE THE BLOCKCHAIN TO AUTOMATE THIS REWARDS SYSTEM.

'ESG HAS BEEN BREWING FOR A WHILE, AND IS HITTING THE MAINSTREAM NOW, DRIVEN BY UNITED DEMAND FROM EMPLOYEES, INVESTORS AND CUSTOMERS.'

-TINE THYGESEN, FORBES.COM

1.5 ORGANIZATION LICENSING

WYOMING'S HOUSE OF REPRESENTATIVES PASSED A BILL THAT "DEFINED UTILITY TOKENS." CRYPTOCURRENCY AND BLOCKCHAIN ADVOCATE CAITLIN LONG, CO-FOUNDER OF THE WYOMING BLOCKCHAIN COALITION, WAS THE LOBBYIST BEHIND MUCH OF THIS LEGISLATION WHICH HELPED MAKE HER STATE ONE OF AMERICA'S PRO-CRYPTO HUBS IN 2018 FOLLOWING SEVEN OTHER BILLS BEING PASSED TO ACKNOWLEDGE DIGITAL CURRENCY AS LEGAL FORM FOR CAPITAL.

LITH LLC & LITH ESG FOUNDATION WILL BE FOUNDED BY A TEAM OF EXPERTS, AND THE BASE OF THE ORGANIZATIONS WILL BE LOCATED IN CHEYENNE, WYOMING. THE TEAM WILL APPLY FOR THE LEGAL RIGHT TO PHYSICALLY OPERATE AS AN ORGANIZATION BY NOVEMBER 2021.

1.6 EVER INCREASING ESG DEMAND

ESG REPORTING COMPLIANCE IS ON THE RISE BECAUSE OF INCREASED SHAREHOLDER INTEREST AND GOVERNMENT POLICIES THAT INTEND TO MITIGATE CLIMATE CHANGE. FORBES REPORTS A QUARTER OF U.S. INVESTMENTS ARE NOW IN ESG COMPANIES, ACCOUNTING FOR 12 TRILLION DOLLARS AS IT BECOMES MORE MAINSTREAM. AS ESG CONTINUES TO BE ACCEPTED BY MANY CORPORATIONS, THEY WILL FACE PRESSURE FROM REGULATORS AND STAKEHOLDERS WHO WANT THEIR DATA STANDARDIZED - THUS MAKING IT EASIER TO COMPARE ACROSS INDUSTRIES. **LITH** HAS ALREADY BEGUN TO STANDARDIZE DATA FOR ESG REPORTING AND IS NOW WORKING ON DEVELOPING A PLATFORM WHICH WILL MAKE IT EASIER FOR COMPANIES TO TRACK AND REPORT THEIR SUSTAINABILITY REPORTS.

DEVELOPMENT PLAN

1.7 ESG SUPPLY CHAIN AUTHENTICATION

(1ST) LITH ESG MARKETPLACE

A MARKETPLACE FOR CONSUMERS AND BUSINESSES TO EXCHANGE LITH TOKEN FOR CERTIFIED PRODUCTS WHICH HAVE ESG INFORMATION READILY AVAILABLE ON THE BLOCKCHAIN.

(2ND) LITH ESG BLOCKCHAIN HUB

THE CENTRAL LOCATION AND ACCESS POINT FOR CONSUMERS & BUSINESSES TO EXCHANGE, ISSUE & AUDIT TOKENS & THE INFORMATION STORED ON THEM.

(3RD) LITH ESG DATABASE API

PRODUCERS, TRANSPORTERS, MERCHANTS & SUPPLIERS ARE PROVIDED A CUSTOMIZED ACCESS POINT TO CONNECT TO THE BLOCKCHAIN HUB IN ORDER TO HAVE THEIR ESG INFORMATION INTEGRATED WITH THE BLOCKCHAIN.

1.8 ESG CONSUMERS & BUSINESSES

83% OF CONSUMERS THINK COMPANIES SHOULD BE ACTIVELY SHAPING ESG BEST PRACTICES.*

91% OF BUSINESS LEADERS BELIEVE THEIR COMPANY HAS A RESPONSIBILITY TO ACT ON ESG ISSUES.*

86% OF EMPLOYEES PREFER TO SUPPORT OR WORK FOR COMPANIES THAT CARE ABOUT THE SAME ISSUES THEY DO.*

*PWC.COM 2021 CONSUMER INTELLIGENCE SERIES SURVEY ON ESG

LITH TOKEN IS A CRYPTOCURRENCY THAT ENABLES COMPANIES TO REWARD EMPLOYEES & CONSUMERS FOR POSITIVE ENVIRONMENTAL IMPACT. IT'S THE FIRST TOKEN ON THE BLOCKCHAIN WHICH ALIGNS THE ECONOMIC INCENTIVES WITH ESG BEST PRACTICES. WE BELIEVE THIS WILL HELP CLOSE THE GAP BETWEEN CONSUMER EXPECTATIONS & BUSINESS ACTIONS.

1.9 LITH TOKEN WALLET

LITH TOKEN IS A CRYPTOCURRENCY THAT INVOKES STRONG MARKET CAPITALIZATION & LIQUIDITY. **LITH TOKEN** CAN BE EXCHANGED FOR THINGS ONLINE OR AS ESG CREDITS IN THE FUTURE WHERE IT WILL BE EXCHANGEABLE WITHIN ALL PARTS OF THIS ECOSYSTEM, VIA OUR SECURE WALLET. **LITH TOKEN** AUTOMATIC MINTING OF NON-FUNGIBLE TOKENS (NFT'S) WILL ALSO TAKE PLACE ON THE BLOCKCHAIN HUB AS PART OF THE SUPPLY CHAIN AUTHENTICATION. **LITH TOKENS** WILL EVENTUALLY ALLOW CONVERSION TO MANY OTHER CURRENCIES, ALL WITHIN THE TOKEN'S SECURE WALLET ON ITS OWN BLOCKCHAIN-POWERED PLATFORM. THE WALLET WILL BE INTEGRATED WITH ALL ASPECTS OF THE LITH ECOSYSTEM, SO AS TO AUTOMATICALLY REWARD ESG CONSUMERS AND BUSINESSES FOR BEING ENVIRONMENTALLY & SOCIALLY CONSCIOUS, AS WELL AS FOR ENGAGING OTHERS WITHIN THE COMMUNITY.

ENVIRONMENTAL SOCIAL GOVERNANCE (ESG)

2.1 WHAT IS ESG?

ESG, OR ENVIRONMENTAL, SOCIAL, AND GOVERNANCE IS A RATINGS SYSTEM EMPLOYED BY MANY COMPANIES TO DETERMINE THE ETHICAL VALUES OF AN ENTERPRISE WITHIN AND OUTSIDE OF ITS ORGANIZATION. ES-RATED COMPANIES ARE SAID TO BE MORE RESPONSIBLE ENVIRONMENT STEWARDS WHILE ALSO HAVING STRONG ETHICAL PRACTICES THAT ENCOURAGE GIVING BACK TO SOCIETY. RESEARCH HAS SHOWN THAT BUSINESSES WHO HAVE STRONG ENVIRONMENT, SOCIAL AND GOVERNANCE FACTORS TEND TO BE MORE PROFITABLE AND SEE GREATER LONG-TERM GROWTH PROSPECTS. ESG RATINGS GIVE INVESTORS, BUSINESSES AND CONSUMERS DATA POINTS THEY CAN USE TO MAKE INFORMED DECISIONS ABOUT WHICH COMPANIES AND PRODUCTS TO PURCHASE AND DO BUSINESS WITH. THE ENVIRONMENTAL, SOCIAL AND GOVERNING FACTORS THAT MAKE UP THE ESG RATINGS ARE DIVIDED INTO SEVENTY-SIX DIFFERENT METRICS. THROUGH A CENTRALIZED SCORING SYSTEM, THESE THREE MAJOR COMPONENTS OF ESG RATINGS HAVE BEEN CATEGORIZED TO GIVE COMPANIES AND INVESTORS AN IDEA OF HOW WELL THEIR COMPANY OR INVESTMENT FARES ON EACH METRIC. CONSUMERS WHO PURCHASE PRODUCTS FROM ESG COMPANIES ARE ALSO REWARDED WITH A BETTER PRODUCT AS THEY KNOW THAT THE ENVIRONMENT, SOCIAL AND GOVERNANCE FACTORS THAT WERE USED TO EVALUATE THE COMPANY AND THEIR PRODUCT ALIGN WITH THEIR BELIEFS. WHILE THIS INFORMATION IS NOT GENERALLY KNOWN TO CONSUMERS, MANY BUSINESSES HAVE BEEN USING IT BEHIND THE SCENES FOR YEARS TO DETERMINE WHICH BUSINESSES ARE MORE ETHICAL THAN OTHERS. **LITH TOKEN** WILL DECENTRALIZE THE SCORING SYSTEM.

2.2 ESG IMPLEMENTATION

EXISTING ESG RATINGS SYSTEMS ARE VERY INEFFICIENT AND BASED ON SUBJECTIVE OPINIONS, NEGATIVELY IMPACTING THE RATINGS THEMSELVES AND THE COST OF OBTAINING RATINGS. BLOCKCHAIN-BASED RATINGS CAN ELIMINATE THESE NEGATIVE IMPACTS WHILE MAKING RATINGS CHEAPER, FASTER AND MORE ACCESSIBLE FOR ALL ORGANIZATIONS WISHING TO OBTAIN RATINGS WHICH ARE VERIFIABLE BY INDEPENDENT RATINGS ORGANIZATIONS. GIVEN NO OTHER RATINGS PROVIDER HAS IMPLEMENTED RATINGS FOR THEIR CLIENTS IN A TRULY DECENTRALIZED BLOCKCHAIN-BASED MANNER, WHICH IS A UNIQUE OPPORTUNITY TO BECOME THE DOMINANT RATINGS PROVIDER AND IMPROVE RATINGS.

LITH TOKEN WILL IMPLEMENT A DECENTRALIZED GOVERNING MODEL IN DECIDING COMPANIES' ESG RATINGS BY USING A VOTING SYSTEM, WHERE EACH VOTE IS RECORDED ON THE BLOCKCHAIN AND CHECKED AGAINST THE ECOSYSTEM'S IMMUTABLE KYC DATABASE. BLOCKCHAIN-BASED RATINGS PROVIDE AN UNBIASED VIEW OF RATINGS ON A COLLECTIVE

DATA SET WHICH CAN BE USED TO IMPROVE RATINGS THROUGH UNIFIED IMPROVEMENT EFFORTS. GIVEN NO OTHER PROVIDER HAS IMPLEMENTED THIS TYPE OF DECENTRALIZED SYSTEM YET - **LITH TOKEN** IS POSITIONED WITH AN OPPORTUNITY TO HAVE A FIRST MOVER ADVANTAGE WITH UNLIMITED POTENTIAL!

2.3 GENERAL ESG CRITERIA

ENVIRONMENTAL

- GREENHOUSE GAS EMISSIONS
- ENERGY USE & EFFICIENCY
- AIR POLLUTANTS
- WATER USE
- WASTE MANAGEMENT (WATER, SOLID & HAZARDOUS)
- USE OF ECOSYSTEMS
- INNOVATION IN ENVIRONMENT-FRIENDLY
- PRODUCTS & SERVICES

SOCIAL

- DIVERSITY & EQUAL OPPORTUNITY
- POVERTY & COMMUNITY IMPACT
- SUPPLY CHAIN MANAGEMENT
- CUSTOMER PRIVACY
- LOCAL COMMUNITIES
- FREEDOM OF ASSOCIATION
- HUMAN RIGHTS

GOVERNANCE

- CODE OF CONDUCT & BUSINESS PRINCIPLES
- ACCOUNTABILITY
- TRANSPARENCY & DISCLOSURE
- BOARD DIVERSITY & STRUCTURE
- BRIBERY & CORRUPTION
- STAKEHOLDER ENGAGEMENT
- SHAREHOLDER RIGHTS

2.4 ESG SURVEYS & RANKINGS

ESG SURVEYS HELP CREATE A DECENTRALIZED STANDARD.

UPON LAUNCHING **LITH ESG API** & **LITH ESG MARKETPLACE** IN THEIR BROWSERS OR IN THEIR APPS, USERS WILL BE PROMPTED TO VOTE FOR WHAT THEY CONSIDER TO BE THE MOST IMPORTANT CRITERIA OF THREE DIFFERENT OPTIONS. THIS POLL WILL BE ABLE TO BE CLOSED WITHOUT THE USERS ANSWERING BUT WILL CONTINUE TO SHOW UP ON EACH LAUNCH UNTIL ALL CRITERIA ARE VOTED ON. THE VOTES WILL BE STORED ON THE BLOCKCHAIN AND EACH USER ACCOUNT IS ALLOWED ONLY ONE VOTE PER SURVEY SET, WHICH HELPS GENERATE WEIGHTED SCORING VIA A RANKING SYSTEM. EACH USER WILL BE ABLE TO ANSWER ALL POLL QUESTIONS AT ONCE IF THEY CHOOSE, AND NEVER SEE THE POLLS AGAIN.

IN THE FUTURE, **LITH** WILL BRING IN A MATHEMATICAL SOCIOLOGIST TO CREATE A QUICK ONE-TIME, 20 QUESTION QUIZ WHICH WILL HELP PROFILE USERS' GENERAL CRITERIA PREFERENCES ACCORDING TO THEIR ANSWERS, AND TO KEEP THINGS ABBREVIATED.

EXAMPLE OF WEIGHTED RANKINGS ACCORDING TO SURVEY RESULTS:

AIR POLLUTANTS: 5/10 POINTS > 54% OF VOTES (12 VOTES FOR AIR POLLUTANTS)

GHG EMISSIONS: 3/10 POINTS > 32% OF VOTES (7 VOTES FOR AIR POLLUTANTS)

USE OF ECOSYSTEM: 2/10 POINTS > 14% OF VOTES (3 VOTES FOR AIR POLLUTANTS)

PERCENTAGE OF CRITERIA VOTES ALLOTS WEIGHT RANKING ON SCALE OF 1 TO 10

⇒

$$\text{ESG SCORE} = \frac{((\text{SCORE A} \times 20) \times \text{WEIGHT A}) + ((\text{SCORE B} \times 20) \times \text{WEIGHT B}) + ((\text{SCORE C} \times 20) \times \text{WEIGHT C})}{100}$$

2.5 ESG REVIEW SYSTEM

ESG REVIEWS ARE THE FUTURE!

LITH ESG MARKETPLACE WILL HAVE A REVIEW SYSTEM IN PLACE TO CREATE AN ESG SCORE FOR ALL PRODUCTS AND SERVICES, WHICH CAN THEN BE ASSESSED THROUGH RANKING BASED OFF STANDARDS SURVEYS - MAKING IT EASY FOR CONSUMERS AND BUSINESSES ALIKE WHO WANT PEACE OF MIND THAT THEY'RE DOING BUSINESS RESPONSIBLY. THE API INTEGRATION WITH BLOCKCHAIN HUB CREATES A SEAMLESS MARKETPLACE WHERE YOU'LL KNOW YOUR INFORMATION IS SAFE FROM THIRD-PARTY HACKING OR FRAUD ATTEMPTS WHILE STILL BEING ABLE TO MAKE INFORMED DECISIONS ABOUT WHAT'S SUSTAINABLE WITHOUT COMPROMISING PRIVACY. THIS ALLOWS EVERYONE ON BOTH SIDE OF THE TABLE EQUAL ACCESS AS WELL AS TRANSPARENCY SO THERE'S NEVER ANY CONFUSION WHEN CONDUCTING TRANSACTIONS ONLINE.

EXAMPLE OF ESG RANKING SYSTEM

COMPANY A:

CATEGORY 1: AIR POLLUTANTS

AVERAGE REVIEW: 3 OF OUT 5 STARS

WEIGHT: 5

CATEGORY 2: GHG EMISSIONS

AVERAGE REVIEW: 4 OUT OF 5 STARS

WEIGHT: 3

CATEGORY 3: USE OF ECOSYSTEMS

AVERAGE REVIEW: 2 OUT OF 5 STARS

WEIGHT: 2

FINAL ESG RATING: 68%

COMPANY B:

CATEGORY 1: AIR POLLUTANTS

AVERAGE REVIEW: 4 OUT OF 5 STARS

WEIGHT: 5

CATEGORY 2: GHG EMISSIONS

AVERAGE REVIEW: 2 OUT OF 5 STARS

WEIGHT: 3

CATEGORY 3: USE OF ECOSYSTEMS

AVERAGE REVIEW: 5 OUT OF 5 STARS

WEIGHT: 2

FINAL ESG RATING: 72%

2.6 SHOPLITH

THE LITH ESG MARKETPLACE (SHOPLITH) WILL PROVIDE A PLATFORM FOR INDIVIDUALS AND ALL SIZES OF BUSINESSES TO SELL PRODUCTS AND SERVICES, DISPLAY BLOCKCHAIN VERIFIED ESG RATINGS, AND DISPLAY PRODUCT AND SERVICES INFORMATION FROM THE ENTIRE SUPPLY CHAIN.

TO UTILIZE THIS PLATFORM, VENDORS MUST MAINTAIN A MINIMUM BALANCE OR TOKENS OF LITH (BASED ON USD VALUE). THIS TIERED COMMISSION SYSTEM ENSURES THAT THOSE WITH LARGER BALANCES PAY LESS FEES - HOLDING <\$1K IN LITH ENABLES LISTINGS AT 10% commission on sales; \$1k-\$4.9999k = 8%; \$5k+ = 5%.

SHOPLITH IS DESIGNED TO ENCOURAGE A CYCLICAL REWARDS SYSTEM BETWEEN CONSUMERS AND MERCHANTS, ALLOWING SHOPPERS TO BE REWARDED IN THE **LITH** MARKETPLACE AS WELL. FOR EVERY REVIEW OR SUBSTANTIAL ENGAGEMENT MADE, CONSUMERS ARE AWARDED A SMALL AMOUNT OF CRYPTOCURRENCY-BASED REWARD CURRENCY TO USE ON THEIR NEXT VISIT.

THE NEW BLOCKCHAIN-BASED REWARDS SYSTEM INCENTIVIZES SHOPPERS FOR ENGAGING WITH MERCHANTS AND WRITING REVIEWS AS WELL AS ENGAGING WITH OTHER CONSUMERS. THIS IS DONE BY ALLOWING THEM ACCESS TO EXCLUSIVE DISCOUNTS IF THEY HAVE HELD AT LEAST \$1000 USD WORTH OF **LITH TOKEN** AS WELL AS GIVING THEM SPECIAL PRIVILEGES SUCH AS PURCHASING FROM “HOT LIST” PRODUCTS BEFORE OTHERS HAVE THE OPPORTUNITY.

2.6.1 PHYSICAL NFT'S + ESG DATA

SHOPLITH PROVIDES AN OPPORTUNITY FOR CREATORS, INDIVIDUALS, AND BUSINESSES ALIKE TO BUY, SELL AND TRADE PHYSICAL GOODS WITH ESG DATA ATTACHED.

USERS WILL HAVE THE OPTION TO BUY, SELL AND TRADE ‘NOT RATED’ AND DIGITAL ONLY PRODUCTS AS NFT'S, AS WELL.

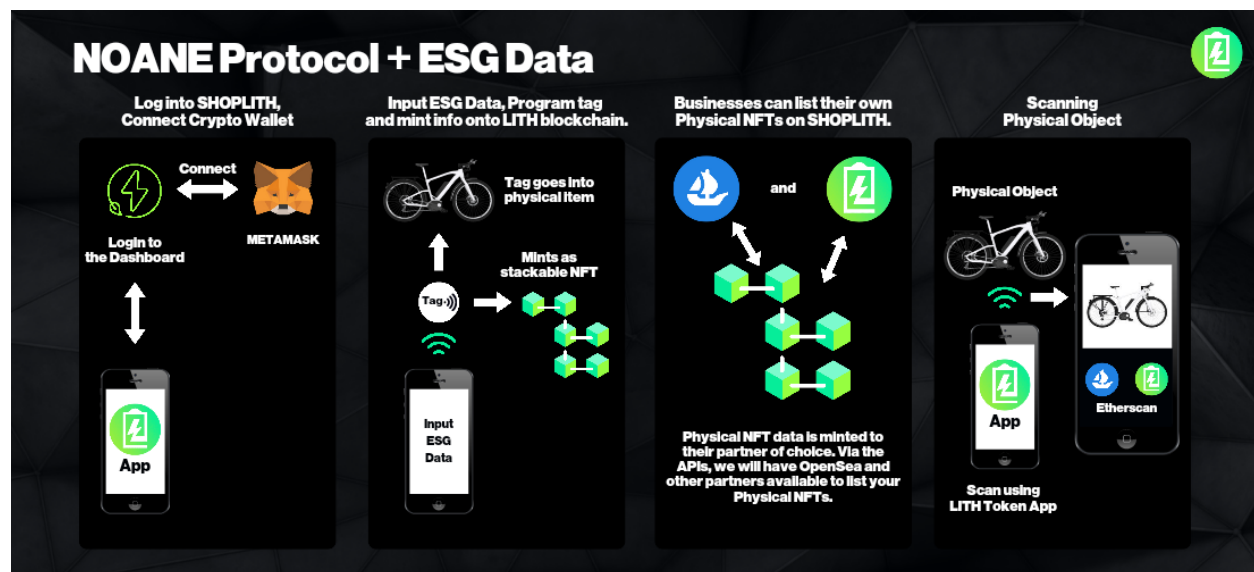

2.7 LITH ESG API

LITH ESG API WILL BE A SERVER-SIDE FRAMEWORK DESIGNED TO INTEGRATE WITH THE **LITH** ECOSYSTEM VIA A BLOCKCHAIN ORACLE. THE API ALLOWS BUSINESSES TO STORE THIRD PARTY DOCUMENTS, ANALYSIS REPORTS, ETC, WHICH ARE THEN STORED IN AN IMMUTABLE DATABASE AS THEY AWAIT VALIDATION BY THE USER. IN ADDITION, IT WILL ALLOW

VENDORS TO ISSUE ERC-1155 NFT'S LINKED TO THEIR ESG REPORTING INITIATIVES WITHIN THE LITH ECOSYSTEM, THUS BRINGING TRANSPARENCY TO THEIR ESG REPORTING.

THE API INCLUDES AN API-SPECIFIC SMART CONTRACT, WHICH WILL OFFER BUSINESSES A SCALABLE METHOD TO SUBMIT DATA THROUGH AN APPLICATION PROGRAMMING INTERFACE (API). API USERS WILL GAIN THE ABILITY TO UTILIZE ESG DATA IN THEIR API ACTIONS.

WHILE THIS API IS INTENDED FOR BUSINESSES, IT COULD BE USED BY ANY INDIVIDUAL WITH AN API KEY IF THEY WERE INTERESTED IN USING ESG DATA AS PART OF ANY OTHER ACTION API INTEGRATION SUCH AS A KYC API.

THE API FRAMEWORK WILL ENABLE USERS TO INTEGRATE THE **LITH ESG API** WITH ANY SOFTWARE/DATA PROCESSING THEY USE, SUCH AS A CRM OR ERP SYSTEM IN ORDER TO HAVE ALL OF THEIR DATA AND API CALL ACTIONS BE ESG RELATED. THE API WILL BE STRUCTURED SO THAT IT WORKS WELL WITHIN EXISTING PROGRAMS IN MULTIPLE INDUSTRIES AND SECTORS - INCLUDING BUT NOT LIMITED TO - MINING, PRODUCTION, FINANCE, INFORMATION TECHNOLOGY, TELECOMMUNICATIONS AND THE PUBLIC SECTOR.

BLOCKCHAIN

3.1 WHY ERC-1155?

ERC-1155 IS AN INEXPENSIVE WAY TO HANDLE TRANSACTIONS ON A BLOCKCHAIN. IT OFFERS SEVERAL FEATURES THAT ARE DESIGNED SPECIFICALLY FOR USE IN CRYPTOCURRENCY WORLD, SUCH AS ATOMIC SWAPS AND TIME LOCKS.

ERC-1155 TOKENS CAN BE USED TO STACK SMART CONTRACTS TOGETHER, THAT CAN BE UTILIZED IN COMBINATION WITH CRON JOBS. MUCH LIKE A CRON JOB, THIS IS ADVANTAGEOUS BECAUSE IT ALLOWS FOR MORE ACCURATE AND EFFICIENT CODING IN THE FUTURE WITH AUTOMATIC TRIGGERING OF PROGRAMS BASED ON PREDETERMINED CRITERIA.

WITH DECENTRALIZATION, COORDINATING WORK AND KEEPING ALL ACTIVITIES ON TRACK IS VERY EFFICIENT. SINCE THE DECISION-MAKING AUTHORITY IS CLOSER TO USERS WITHIN THE **LITH** ECOSYSTEM, QUICKER DECISIONS CAN BE MADE. THESE DECISIONS ARE OFTEN WISER AND MORE ACCURATE, TOO! WITH ERC-1155, TOKENS BEING USED AS A MEDIUM OF EXCHANGE, WITH ESG SCORES FOR BOTH CONSUMERS AND BUSINESSES ALIKE, IT WILL HELP REAL TIME BUSINESS TRANSACTIONS EASIER THAN EVER BEFORE...FINALLY HOLDING COMPANIES ACCOUNTABLE FOR THEIR ENVIRONMENTAL IMPACT BY USING BLOCKCHAIN TECHNOLOGY THAT'S NOT CONTROLLED BY ANY SINGLE ENTITY. INSTEAD, IT'S CONTROLLED THROUGH CONSENSUS AMONG ITS PARTICIPANTS SO THEY'LL NEVER HAVE TO WORRY ABOUT LOOPHOLES OR POTENTIAL ERRORS WHICH MAY OTHERWISE OCCUR.

SMART CONTRACTS

THE BENEFITS OF AUTOMATIZATION ARE MANY. THIS PROCESS IS CURRENTLY LONG AND TEDIOUS AND WILL BE SPED UP WITH SMART CONTRACTS. THIS WILL RESULT IN A DECREASE IN COST, TIME AND ERRORS FOR ALL PARTIES. THIS INCLUDES COMPANIES AS WELL AS ANYONE WHO CARRIES OUT TRANSACTIONS DAY TO DAY - I.E. YOU!

DECENTRALIZATION

DECENTRALIZATION IS THE MOVEMENT AWAY FROM A SINGLE CENTRAL AUTHORITY TO A MORE DISTRIBUTED POWER. NOT ONLY DOES THIS PROCESS EMPOWER INDIVIDUALS, IT ALSO CAN MAKE GOVERNING AND SOCIAL ISSUES EASIER TO SOLVE BECAUSE THERE ARE FEWER POINTS OF CONTENTION.

FUNGIBLE/NON-FUNGIBLE

IMAGINE BEING ABLE TO USE ONE TOKEN FOR EVERYTHING - THAT'S EXACTLY WHAT ENGINEERS REALIZED WHEN THEY CREATED THE UNIVERSAL CRYPTOCURRENCY - WHICH CAN BE USED AS BOTH FUNGIBLE AND NON-FUNGIBLE TOKENS AT DIFFERENT TIMES IN ORDER TO FIT ANY NEED THAT MAY ARISE.

SECURITY/ENCRYPTION

THE BLOCKCHAIN IS A DECENTRALIZED, ENCRYPTED LEDGER. IT'S MORE SECURE THAN THE REGULAR RECORD KEEPING SYSTEM BECAUSE TRANSACTIONS MUST BE AGREED UPON BEFORE THEY'RE RECORDED. THIS OFFERS AN IMMUTABLE RECORD FOR ALL TRANSACTIONS.

PEER-TO-PEER TRANSACTIONS

THERE WILL BE NO MORE TIME WASTED WAITING FOR TRANSFERS TO CLEAR. YOU CAN BUY, SELL, TRANSFER AND USE **LITH TOKEN** FOR PURCHASES WITH A CLICK OF THE MOUSE OR SWIPE ON YOUR MOBILE DEVICE.

SUPPLY CHAIN TRANSPARENCY

WITH THE HELP OF A DISTRIBUTED LEDGER, INFORMATION IS STORED AND VERIFIED WITH EASE. IT ALSO PROVIDES MANY BENEFITS TO ITS USERS BY BEING AN IMMUTABLE SOLUTION CAPABLE OF STORING DATA THAT CANNOT BE HACKED OR ERASED WITHOUT DETECTION.

3.2 BLOCKCHAIN HUB

THE LITH TOKEN BLOCKCHAIN HUB WILL BE ACTING AS THE CENTRAL ASPECT TO THE ESG BLOCKCHAIN ECOSYSTEM/PLATFORM. LITH TOKEN'S ERC-1155 SMART CONTRACT WILL BE HELD IN PLACE ON THE LITH BLOCKCHAIN HUB, WITH MANY OTHER IMPORTANT FEATURES. LITH TOKENS WILL BE PURCHASABLE THROUGH THE USERS' DASHBOARDS AND USERS WILL BE ABLE TO SEE THE MOST UP TO DATE NOTIFICATIONS ON SUPPLY CHAIN INFORMATION.

THE BLOCKCHAIN HUB WILL INCLUDE:

(1) A BLOCK EXPLORER FOR CHECKING TRANSACTIONS AND THE **LITH TOKEN** BALANCE. (2) **LITH TOKEN'S** ERC-1155 SMART CONTRACT WILL BE HELD IN PLACE (3) A WALLET FOR **LITH TOKENS** (ALLOWING FOR REGISTERED PARTIES TO ISSUE **LITH TOKENS** FOR SUPPLY CHAIN PURPOSES, AS WELL AS DIRECTLY PURCHASING **LITH TOKENS** FROM THE BLOCKCHAIN HUB.) (4) **LITH TOKEN** DIRECT PURCHASE: THIS IS NECESSARY AS **LITH TOKEN** HOLDERS WILL DESIRE THE ABILITY TO PURCHASE **LITH TOKENS** TO USE FOR STORING ESG DATA AS WELL AS BUYING PRODUCTS FROM THE ESG MARKETPLACE (**SHOPLITH**) (5) A DASHBOARD: ALL **LITH TOKEN** SALES OR DISTRIBUTIONS WILL BE ACCESSIBLE THROUGH THIS INTERFACE.

LITH TOKEN PURCHASERS, **LITH TOKEN** ISSUERS AND **LITH TOKEN** HOLDERS WILL BE ABLE TO VIEW THEIR **LITH TOKEN** PORTFOLIO BALANCE, WHICH CAN INCLUDE A BREAKDOWN OF WHICH **LITH TOKENS** THEY OWN. (6) A KNOWLEDGE BASE (BLOG): **LITH TOKEN** WANTS TO CREATE THE MOST UP TO DATE LEARNING CENTER FOR ESG **LITH TOKEN** BLOCKCHAIN INFORMATION. **LITH TOKEN** IS REACHING OUT TO LEADING EXPERTS IN MANY FIELDS ACCOMPLISH THIS. (7) AN ESG RATING SYSTEM. (8) ESG RATING PLATFORM FOR FINDING BUSINESSES THAT ARE ESG COMPLIANT. THE ESG RATING PLATFORM WILL HAVE A BUILT IN WALLET SO USERS CAN PURCHASE PRODUCTS DIRECTLY FROM THE ESG MARKETPLACE (**SHOPLITH**). (9) **LITH TOKENS** WILL BE USED AS ESG TOKENS ON THE ESG RATING PLATFORM. THE ESG RATING PLATFORM WILL ALSO HAVE KNOWLEDGE BASE AND BLOG FOR ESG INFORMATION, WITH THE MAIN FOCUS BEING ESG-RELATED BLOCKCHAIN TECHNOLOGY. (10) THE ESG RATING PLATFORM WILL SHOW ESG RATINGS FROM ESG RATED BUSINESSES WITHOUT ESG RATINGS. BUSINESSES THAT ARE NOT ESG RATED WILL HAVE A SCORE OF 0 ON THE ESG RATING PLATFORM, UNLESS THEY CLAIM OTHERWISE. ESG RATED PRODUCTS CAN BE FOUND ON THE ESG MARKETPLACE (**SHOPLITH**), WHERE ESG RATED BUSINESSES A SCORE AND USERS WILL BE ABLE TO PURCHASE ESG RATED PRODUCTS THAT ARE ESG COMPLIANT. (11) ESG BUSINESSES WILL BE ABLE TO PURCHASE ESG RATINGS FOR THEIR ESG PRODUCTS DIRECTLY ON THE ESG RATING PLATFORM WITHIN THE BLOCKCHAIN HUB. (12) THE ESG RATING PLATFORM WILL HAVE A LIST OF ALL ESG RATED BUSINESS AS WELL AS A LINK TO THEIR MERCHANT LISTING ON **SHOPLITH** IN ORDER TO MAKE IT EASIER FOR USERS TO FIND THE ESG RATED BUSINESS. USERS CAN THEN PURCHASE ESG COMPLIANT PRODUCTS THROUGH THE ESG MARKETPLACE (**SHOPLITH**). ESG RATINGS WILL BE ACCUMULATED IN THE ESG RATING SYSTEM.

THE ESG RATING SYSTEM WILL HAVE TWO MAIN CATEGORIES: ESG COMPLIANT BUSINESSES AND ESG RATED BUSINESSES THAT ARE NOT ESG COMPLIANT.

3.3 NOANE PROTOCOL

NFC ORACLIZED ASSYMETRIC NFT ENCRYPTION (NOANE) IS A UNIQUE PHYSICAL NFT PROCESS WHICH IS IN PATENT PENDING STATUS AND CARRIES MANY POSITIVE REPERCUSSIONS IN CORRELATION WITH DEVICE COMMUNICATIONS WITH THE BLOCKCHAIN. THIS PROCESS CREATES A TRUE MARRIAGE BETWEEN PHYSICAL/ TANGIBLE ITEMS AND THE BLOCKCHAIN, AND PROVIDES ADDITIONAL LAYERS OF PROOF OF OWNERSHIP, ANTI-COUNTERFEITING AND SUPPLY CHAIN TRACKING, WHICH IS NECESSARY IN ORDER TO TRULY INTEGRATE TANGIBLE ITEMS WITHIN THE METAVERSE AND WEB 3.0 APPLICATIONS.

GENERATING AND MAINTAINING DIGITAL TOKENS ON A BLOCKCHAIN USING PHYSICAL IDENTIFIERS

INTRODUCTION

[0001] ASPECTS OF THE PRESENT DISCLOSURE RELATE TO DIGITAL TOKENS THAT CORRESPOND TO OTHER ASSETS, AND MORE SPECIFICALLY TO THE GENERATION AND MAINTENANCE OF DIGITAL TOKENS ON A BLOCKCHAIN.

BACKGROUND

[0002] DISTRIBUTED LEDGERS, SUCH AS BLOCKCHAINS, HASH CHAINS, AND OTHER LEDGER SYSTEMS, GENERALLY PROVIDE MECHANISMS FOR TRACKING A TRANSACTION HISTORY ASSOCIATED WITH A PHYSICAL OR DIGITAL OBJECT. A DISTRIBUTED LEDGER MAY STRUCTURE A TRANSACTION HISTORY FOR AN OBJECT AS A PLURALITY OF NODES ORDERED SEQUENTIALLY. AN ORIGINAL TRANSACTION IN THE DISTRIBUTED LEDGER, REPRESENTING THE CREATION OF THE OBJECT, MAY BE A NODE THAT DOES NOT POINT TO ANY OTHER NODE IN THE DISTRIBUTED LEDGER AS A PREDECESSOR NODE. SUBSEQUENT TRANSACTIONS MAY BE REACHED BY TRAVERSING POINTERS FROM THE NODE REPRESENTING THE ORIGINAL TRANSACTION TO A NODE REPRESENTING ANY SPECIFIC TRANSACTION. USING THE DISTRIBUTED LEDGER, TRANSACTIONS MAY BE PROCESSED BY ENSURING THAT THE OBJECT IDENTIFIED IN A TRANSACTION EXISTS IN THE DISTRIBUTED LEDGER (E.G., TO VERIFY THAT AN OBJECT EXISTS AND/OR IS A VALID OBJECT AGAINST WHICH TRANSACTIONS MAY OCCUR) AND TO ENSURE THAT THE PARTICIPANTS IN A TRANSACTION ARE ENTITLED TO PERFORM THE TRANSACTION.

[0003] IN SOME CASES, THESE DISTRIBUTED LEDGERS CAN BE USED TO MAINTAIN TRANSACTION HISTORIES FOR DIGITAL TOKENS THAT MAY BE ASSOCIATED WITH OTHER (PHYSICAL OR VIRTUAL) ASSETS. GENERALLY, TRANSFERRING OWNERSHIP OF THESE ASSETS MAY INCLUDE TRANSFERRING BOTH THE UNDERLYING ASSET AND THE DIGITAL TOKEN ASSOCIATED WITH THAT ASSET. A TRANSFER OF A DIGITAL TOKEN MAY GENERALLY BE EFFECTUATED BY TRANSFERRING A TOKEN FROM THE CURRENT OWNER'S WALLET TO THE NEW OWNER'S WALLET BASED ON ENCRYPTION KEYS ASSOCIATED WITH THE CURRENT OWNER AND THE NEW OWNER. HOWEVER, WHEN INFORMATION ABOUT THE UNDERLYING ASSET ASSOCIATED WITH THE DIGITAL TOKEN IS STORED IN AN UNENCRYPTED FORMAT OR ENCRYPTED USING A COMPROMISED ENCRYPTION KEY, IT MAY BE POSSIBLE FOR MALICIOUS OR UNAUTHORIZED USERS TO ACCESS AND REPLICATE THE UNDERLYING ASSET.

[0004] ACCORDINGLY, TECHNIQUES ARE NEEDED TO SECURELY GENERATE AND MAINTAIN DIGITAL TOKENS ON A BLOCKCHAIN.

BRIEF SUMMARY

[0005] CERTAIN EMBODIMENTS PROVIDE A COMPUTER-IMPLEMENTED METHOD FOR GENERATING DIGITAL TOKENS ASSOCIATED WITH AN ASSET ON A BLOCKCHAIN. AN EXAMPLE METHOD GENERALLY INCLUDES RECEIVING A REQUEST TO CREATE A DIGITAL TOKEN CORRESPONDING TO AN ASSET. A FIRST PRIVATE KEY IS RECEIVED. THIS FIRST PRIVATE KEY MAY BE ASSOCIATED WITH A WALLET IN WHICH THE DIGITAL TOKEN IS TO BE STORED. A SECOND PRIVATE KEY IS RECEIVED FROM A PHYSICAL DEVICE ASSOCIATED WITH AN OWNER OF THE ASSET. AN ADDRESS OF THE ASSET IS ENCRYPTED WITH A PUBLIC KEY ASSOCIATED WITH THE SECOND PRIVATE KEY. METADATA ASSOCIATED WITH THE DIGITAL TOKEN IS ENCRYPTED WITH A PUBLIC KEY ASSOCIATED WITH THE FIRST PRIVATE KEY. THE DIGITAL TOKEN IS MINTED ON A BLOCKCHAIN BASED ON THE ENCRYPTED ADDRESS OF THE ASSET AND THE ENCRYPTED METADATA.

[0006] OTHER EMBODIMENTS PROVIDE PROCESSING SYSTEMS CONFIGURED TO PERFORM THE AFOREMENTIONED METHODS AS WELL AS THOSE DESCRIBED HEREIN; NON-TRANSITORY, COMPUTER-READABLE MEDIA COMPRISING INSTRUCTIONS THAT, WHEN EXECUTED BY ONE OR MORE PROCESSORS OF A PROCESSING SYSTEM, CAUSE THE PROCESSING SYSTEM TO PERFORM THE AFOREMENTIONED METHODS AS WELL AS THOSE DESCRIBED HEREIN; A COMPUTER PROGRAM PRODUCT EMBODIED ON A COMPUTER READABLE STORAGE MEDIUM COMPRISING CODE FOR PERFORMING THE AFOREMENTIONED METHODS AS WELL AS THOSE FURTHER DESCRIBED HEREIN; AND A PROCESSING SYSTEM COMPRISING MEANS FOR PERFORMING THE AFOREMENTIONED METHODS AS WELL AS THOSE FURTHER DESCRIBED HEREIN.

[0007] THE FOLLOWING DESCRIPTION AND THE RELATED DRAWINGS SET FORTH IN DETAIL CERTAIN ILLUSTRATIVE FEATURES OF ONE OR MORE EMBODIMENTS.

BRIEF DESCRIPTION OF THE DRAWINGS

[0008] THE APPENDED FIGURES DEPICT CERTAIN ASPECTS OF THE ONE OR MORE EMBODIMENTS AND ARE THEREFORE NOT TO BE CONSIDERED LIMITING OF THE SCOPE OF THIS DISCLOSURE.

[0009] FIG. 1 ILLUSTRATES AN EXAMPLE SYSTEM IN WHICH DIGITAL TOKENS CORRESPONDING TO OTHER ASSETS ARE GENERATED AND MAINTAINED BASED ON PHYSICAL DEVICE IDENTIFIERS.

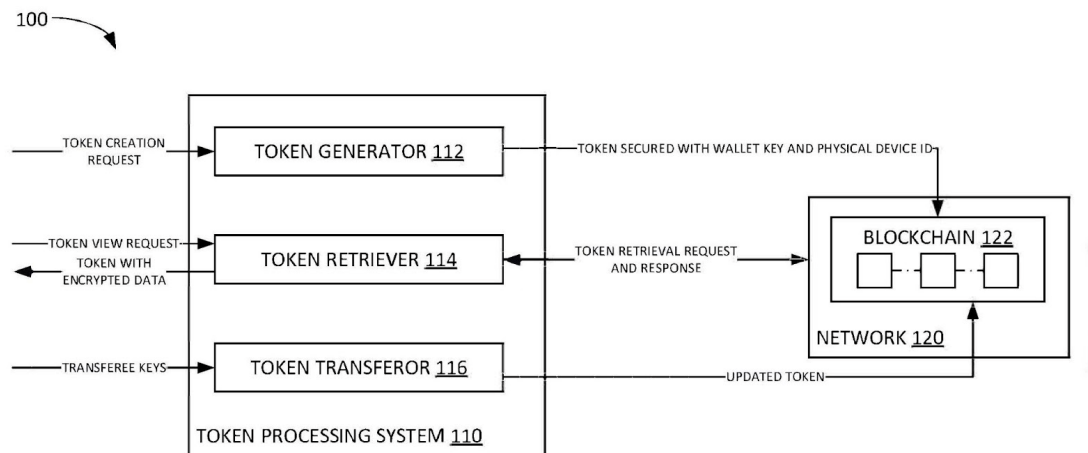

FIG. 1

[0010] FIG. 2 ILLUSTRATES AN EXAMPLE PIPELINE FOR GENERATING A DIGITAL TOKEN BASED ON A PHYSICAL DEVICE IDENTIFIER.

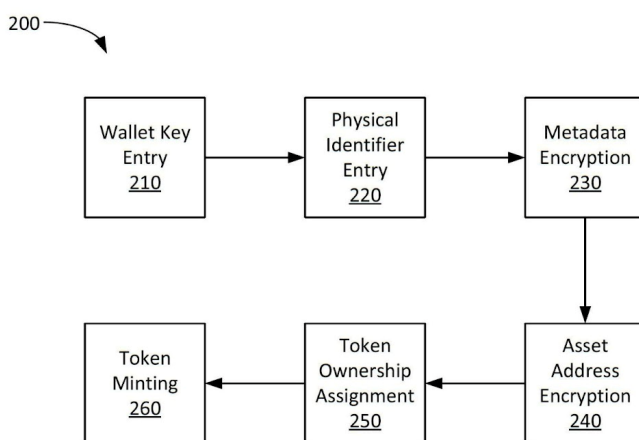

FIG. 2

[0011] FIG. 3 ILLUSTRATES EXAMPLE OPERATIONS FOR GENERATING DIGITAL TOKENS CORRESPONDING TO OTHER ASSETS BASED ON PHYSICAL DEVICE IDENTIFIERS.

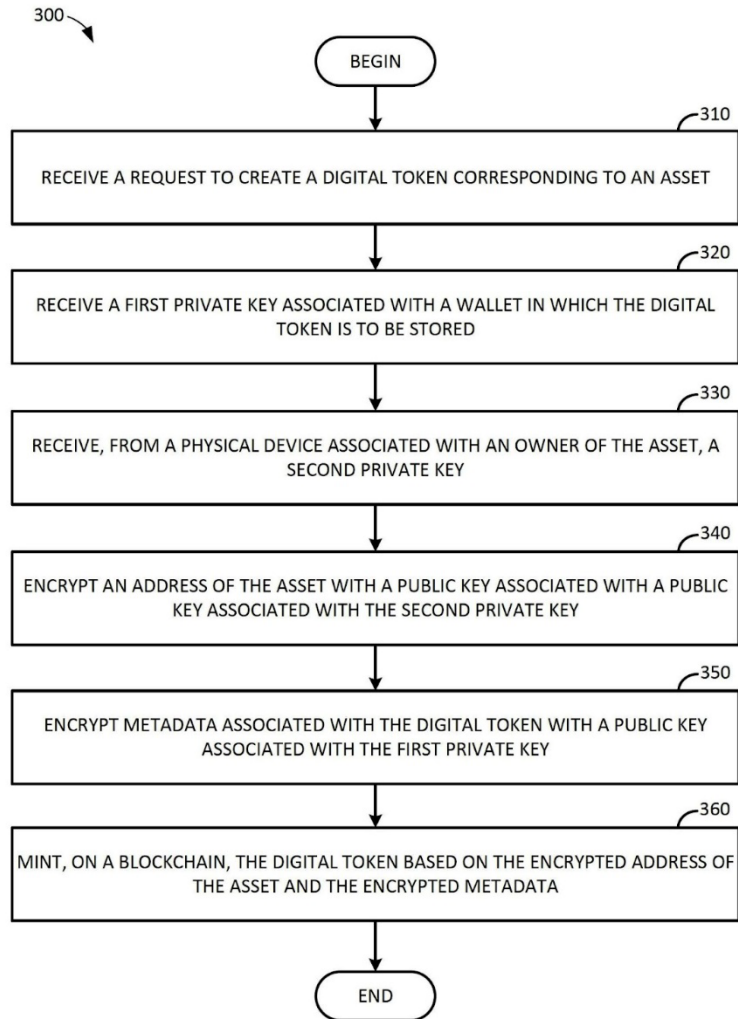

FIG. 3

[0012] FIG. 4 ILLUSTRATES AN EXAMPLE SYSTEM ON WHICH EMBODIMENTS OF THE PRESENT DISCLOSURE CAN BE PERFORMED.

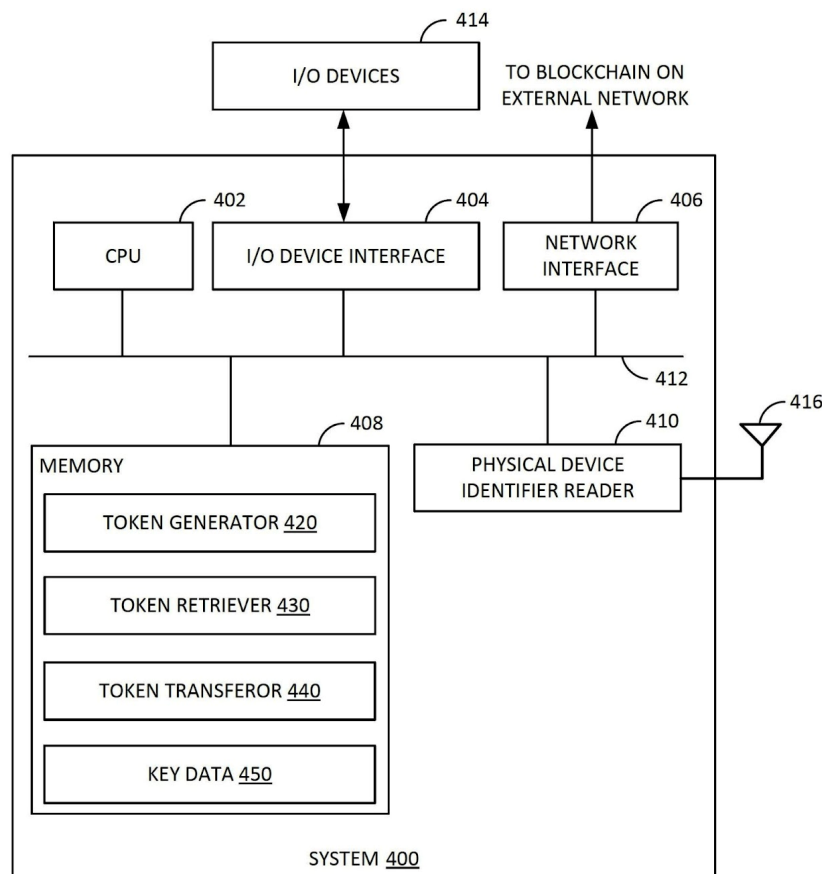

FIG. 4

[0013] TO FACILITATE UNDERSTANDING, IDENTICAL REFERENCE NUMERALS HAVE BEEN USED, WHERE POSSIBLE, TO DESIGNATE IDENTICAL ELEMENTS THAT ARE COMMON TO THE DRAWINGS. IT IS CONTEMPLATED THAT ELEMENTS AND FEATURES OF ONE EMBODIMENT MAY BE BENEFICIALLY INCORPORATED IN OTHER EMBODIMENTS WITHOUT FURTHER RECITATION.

DETAILED DESCRIPTION

[0014] DIGITAL TOKENS STORED ON A BLOCKCHAIN GENERALLY ALLOW FOR THE MAINTENANCE AND TRANSFER OF OWNERSHIP OF VARIOUS ASSETS IN A TRACEABLE MANNER. THESE TOKENS MAY BE NON-FUNGIBLE TOKENS (NFTS), OR UNIQUE TOKENS REPRESENTING OWNERSHIP OF A SPECIFIC ASSET, SUCH AS A SPECIFIC PIECE OF ARTWORK, A TICKET TO AN EVENT, SPECIFIC DATA, OR THE LIKE, WHICH MAY NOT BE DIVIDED INTO SMALLER PORTIONS OR INTERCHANGED WITH OTHER TOKENS. BECAUSE THESE TOKENS MAY NOT BE INTERCHANGEABLE WITH OTHER TOKENS, VARIOUS STEPS MAY BE TAKEN TO PREVENT REPLICATION OF THESE TOKENS. FOR EXAMPLE, INFORMATION IN THE TOKEN MAY BE ENCRYPTED USING ENCRYPTION SYSTEMS SO THAT ONLY THE OWNER OF THE TOKEN CAN

ACCESS THE TOKEN. FOR EXAMPLE, PUBLIC-PRIVATE KEY ENCRYPTION SYSTEMS GENERALLY ALLOW FOR THE DIGITAL TOKENS TO BE ENCRYPTED USING THE OWNER'S PUBLIC KEY SO THAT ONLY A PARTY WITH THE OWNER'S PRIVATE KEY CAN DECRYPT THE DIGITAL TOKEN AND VIEW ITS CONTENT.

[0015] COMPROMISE OF THE OWNER'S PRIVATE KEY MAY, HOWEVER, ALLOW FOR MALICIOUS OR UNAUTHORIZED USERS TO ACCESS A DIGITAL TOKEN, PERFORM AN UNAUTHORIZED TRANSFER OF THE DIGITAL TOKEN TO ANOTHER USER, GENERATE UNAUTHORIZED COPIES OF THE DIGITAL TOKEN, OR THE LIKE. FOR EXAMPLE, IF A DIGITAL TOKEN CORRESPONDING TO A PIECE OF DIGITAL ARTWORK INCLUDES INFORMATION IDENTIFYING THE LOCATION OF THE PIECE OF DIGITAL ARTWORK (E.G., A UNIFORM RESOURCE LOCATOR (URL) OR UNIFORM RESOURCE IDENTIFIER (URI)) AND THE DIGITAL TOKEN IS ENCRYPTED USING A COMPROMISED KEY, A MALICIOUS USER CAN ACCESS THE UNDERLYING PIECE OF DIGITAL ARTWORK AND EFFECTIVELY COUNTERFEIT THE PIECE OF DIGITAL ARTWORK. BY PERFORMING UNAUTHORIZED TRANSFERS OF A DIGITAL TOKEN OR COUNTERFEITING THE UNDERLYING ASSET, THE LINK ASSOCIATING OWNERSHIP OF THE DIGITAL TOKEN WITH OWNERSHIP OF THE UNDERLYING ASSET, WHETHER PHYSICAL OR DIGITAL, MAY BE BROKEN. IN ANOTHER EXAMPLE, IF A DIGITAL TOKEN ENCRYPTED USING A COMPROMISED KEY INCLUDES SENSITIVE INFORMATION, A MALICIOUS USER CAN ACCESS THIS SENSITIVE INFORMATION AND USE THE SENSITIVE INFORMATION FOR UNAUTHORIZED OR MALICIOUS PURPOSES.

[0016] ASPECTS OF THE PRESENT DISCLOSURE PROVIDE TECHNIQUES FOR SECURELY GENERATING AND MAINTAINING DIGITAL TOKENS. AS DISCUSSED IN FURTHER DETAIL HEREIN, DIGITAL TOKENS MAY BE GENERATED BASED ON DATA ENCRYPTED USING MULTIPLE ENCRYPTION KEYS. ONE OF THESE ENCRYPTION KEYS MAY BE THE PUBLIC KEY CORRESPONDING TO A PRIVATE KEY ASSOCIATED WITH AN OWNER OF AN ASSET ASSOCIATED WITH THE DIGITAL TOKEN, AND ANOTHER ONE OF THESE ENCRYPTION KEYS MAY BE A PUBLIC KEY CORRESPONDING TO A PRIVATE KEY FROM A PHYSICAL DEVICE ASSOCIATED WITH THE OWNER OF THE ASSET. DIFFERENT INFORMATION IN THE DIGITAL TOKEN CAN BE ENCRYPTED USING DIFFERENT KEYS, AND THUS, IF ONE KEY IS COMPROMISED, ONLY A PORTION OF THE DATA IN THE DIGITAL TOKEN MAY BE COMPROMISED, AND OTHER DATA IN THE TOKEN MAY BE PROTECTED. FOR EXAMPLE, IF THE KEY USED TO ENCRYPT THE METADATA IN THE DIGITAL TOKEN IS COMPROMISED, BUT THE KEY USED TO ENCRYPT THE ADDRESS AT WHICH THE ASSET IS LOCATED IS NOT COMPROMISED, A MALICIOUS PARTY MAY NOT BE ABLE TO ACCESS AND COPY THE UNDERLYING ASSET ASSOCIATED WITH THE DIGITAL TOKEN OR CREATE A TOKEN WITH A VALID REFERENCE TO THE ADDRESS AT WHICH THE ASSET IS LOCATED. BY GENERATING DIGITAL TOKENS USING MULTIPLE KEYS, ASPECTS OF THE PRESENT DISCLOSURE CAN IMPROVE THE SECURITY OF DIGITAL TOKENS STORED ON A BLOCKCHAIN, AS MULTIPLE KEYS MAY BE NEEDED TO COMPROMISE A DIGITAL TOKEN. BECAUSE COMPROMISING MULTIPLE KEYS MAY BE A COMPUTATIONALLY INEFFICIENT PROCESS (E.G., A BRUTE FORCE ATTACK ON A 128-BIT KEY WOULD REQUIRE $2^{128} = 3.4E38$ DECRYPTION ATTEMPTS), THE USE OF MULTIPLE KEYS MAY INCREASE THE COMPUTATIONAL EXPENSE OF BREAKING THE ENCRYPTION USED ON THE DATA STORED IN A DIGITAL TOKEN SUCH THAT DOING SO WOULD BE IMPRACTICABLE AT BEST.

EXAMPLE GENERATION AND MAINTENANCE OF DIGITAL TOKENS BASED ON PHYSICAL DEVICE IDENTIFIERS

[0017] FIG. 1 ILLUSTRATES AN EXAMPLE COMPUTING ENVIRONMENT 100 IN WHICH DIGITAL TOKENS CORRESPONDING TO OTHER ASSETS ARE GENERATED AND MAINTAINED USING PHYSICAL DEVICE IDENTIFIERS AS ONE KEY IN A SET OF KEYS USED TO ENCRYPT THE DATA WITHIN A DIGITAL TOKEN. AS ILLUSTRATED, COMPUTING ENVIRONMENT 100 INCLUDES A TOKEN PROCESSING SYSTEM AND A NETWORK 120.

[0018] TOKEN PROCESSING SYSTEM 110 GENERALLY ALLOWS FOR THE GENERATION, RETRIEVAL, AND TRANSFER OF DIGITAL TOKENS USING MULTIPLE ENCRYPTION KEYS TO PROTECT THE SECURITY OF THE DATA STORED IN A DIGITAL TOKEN. GENERALLY, TOKEN PROCESSING SYSTEM 110 MAY BE ANY COMPUTING DEVICE THAT CAN GENERATE DIGITAL TOKENS AND GENERATE CORRESPONDING BLOCKS IN A BLOCKCHAIN TO EVIDENCE THE CREATION AND/OR TRANSFER OF A DIGITAL TOKEN AND ASSETS ASSOCIATED WITH THE DIGITAL TOKEN, SUCH AS A SERVER, A COMPUTE CLUSTER, DESKTOP COMPUTERS, LAPTOP COMPUTERS, MOBILE COMPUTING DEVICES, EDGE COMPUTING DEVICES, OR THE LIKE. FOR EXAMPLE, TOKEN PROCESSING SYSTEM 110 MAY BE CONFIGURED TO PROCESS TRANSACTIONS FOR A CRYPTOCURRENCY NETWORK, SUCH AS NETWORK 120. BY WAY OF EXAMPLE, NETWORK 120 MAY BE AN ETHEREUM® NETWORK OR OTHER CRYPTOCURRENCY NETWORK ON WHICH SMART CONTRACTS CAN BE DEFINED AND EXECUTED FOR THE GENERATION OF UNIQUE DIGITAL TOKENS CORRESPONDING TO OWNERSHIP OR CONTROL OVER AN ASSOCIATED ASSET. AS ILLUSTRATED, TOKEN PROCESSING SYSTEM 110 INCLUDES A TOKEN GENERATOR 112, A TOKEN RETRIEVER 114, AND TOKEN TRANSFEROR 116.

[0019] TOKEN GENERATOR 112 GENERALLY USES A KEY ASSOCIATED WITH A DIGITAL WALLET OF THE OWNER OF AN ASSET AND A KEY ASSOCIATED WITH A PHYSICAL DEVICE OWNED BY THE OWNER OF THE ASSET TO GENERATE (OR “MINT”) A DIGITAL TOKEN CORRESPONDING TO THE UNDERLYING ASSET. THE GENERATED (OR “MINTED”) TOKEN MAY BE COMMITTED TO THE DIGITAL WALLET OF THE OWNER OF THE ASSET, AND A CORRESPONDING RECORD MAY BE RECORDED ON A BLOCKCHAIN TO EVIDENCE THE CREATION AND INITIAL OWNERSHIP OF THE DIGITAL TOKEN AND THE UNDERLYING ASSET.

[0020] A USER CAN REQUEST GENERATION OF A DIGITAL TOKEN ASSOCIATED WITH AN ASSET - WHETHER PHYSICAL OR DIGITAL - BY PROVIDING INFORMATION ABOUT THE UNDERLYING ASSET, A FIRST PRIVATE KEY, AND A SECOND PRIVATE KEY. AS DISCUSSED IN FURTHER DETAIL BELOW, THE FIRST PRIVATE KEY MAY BE ASSOCIATED WITH A WALLET OWNED BY THE OWNER OF THE ASSET, AND THE SECOND PRIVATE KEY MAY BE ASSOCIATED WITH A PHYSICAL DEVICE OWNED BY THE OWNER OF THE ASSET.

[0021] IN SOME ASPECTS, THE ASSET FOR WHICH A DIGITAL TOKEN IS TO BE GENERATED MAY BE A DIGITAL ASSET, SUCH AS DIGITAL ARTWORK DIGITAL EVENT TICKETS, DIGITAL AUDIO AND/OR VIDEO FILES, SENSITIVE DATA USED TO GENERATE PUBLICLY-FACING REPORTS (E.G., ENVIRONMENTAL, SOCIAL, AND GOVERNANCE (ESG) REPORTS), OR THE LIKE. DIGITAL ASSETS MAY BE STORED SEPARATELY FROM DIGITAL TOKENS STORED ON BLOCKCHAIN 122 (E.G., STORED “OFF-CHAIN”), AND THE INFORMATION ABOUT THE UNDERLYING ASSET MAY INCLUDE INFORMATION IDENTIFYING A LOCATION AT WHICH THE DIGITAL ASSET IS STORED. FOR EXAMPLE, THESE DIGITAL ASSETS MAY BE IDENTIFIED BY A UNIFORM RESOURCE LOCATOR (URL) AT WHICH THE DIGITAL ASSET IS STORED, A UNIFORM

RESOURCE IDENTIFIER (URI), A CONTENT IDENTIFIER IN A DISTRIBUTED FILE SYSTEM (E.G., INTERPLANETARY FILE SYSTEM (IPFS) OR THE LIKE), AND SO ON.

[0022] IN OTHER ASPECTS, THE ASSET FOR WHICH A DIGITAL TOKEN IS TO BE GENERATED MAY BE A PHYSICAL ASSET. THE INFORMATION ABOUT THE PHYSICAL ASSET USED TO GENERATE THE DIGITAL TOKEN EVIDENCING OWNERSHIP OF SUCH AN ASSET MAY INCLUDE VARIOUS DIGITAL COUNTERPARTS TO THE PHYSICAL ASSET, SUCH AS A PICTURE OF THE PHYSICAL ASSET, A DIGITAL FILE INCLUDING IDENTIFYING INFORMATION OF THE PHYSICAL ASSET, OR THE LIKE. WHERE A DIGITAL COUNTERPART EXISTS FOR THE PHYSICAL ASSET, THE INFORMATION ABOUT THE UNDERLYING ASSET MAY, SIMILARLY TO A DIGITAL ASSET, IDENTIFY A LOCATION AT WHICH THE DIGITAL ASSET IS STORED. IN SOME ASPECTS, WHERE NO DIGITAL COUNTERPART EXISTS FOR THE PHYSICAL ASSET, THE INFORMATION ABOUT THE UNDERLYING ASSET MAY INCLUDE INFORMATION THAT CAN BE USED TO ACCESS THE PHYSICAL ASSET, SUCH AS A SECURITY CODE, A LOCK COMBINATION, ETC.

[0023] TOKEN GENERATOR 112 MAY PROMPT A USER, IN RESPONSE TO A REQUEST TO GENERATE A DIGITAL TOKEN CORRESPONDING TO AN ASSET, TO PROVIDE A FIRST PRIVATE KEY FOR USE IN ENCRYPTING METADATA ASSOCIATED WITH THE DIGITAL TOKEN. THE FIRST PRIVATE KEY MAY BE A PRIVATE KEY ASSOCIATED WITH A WALLET IN WHICH THE DIGITAL TOKEN IS TO BE STORED. TOKEN GENERATOR 112 CAN SUBSEQUENTLY GENERATE A CORRESPONDING FIRST PUBLIC KEY USING VARIOUS KEY GENERATION ALGORITHMS SUCH THAT ANY DATA ENCRYPTED USING THE FIRST PUBLIC KEY IS DECRYPTABLE USING THE FIRST PRIVATE KEY (E.G., THE PRIVATE KEY ASSOCIATED WITH THE WALLET IN WHICH THE DIGITAL TOKEN IS TO BE STORED). IN SOME ASPECTS, TOKEN GENERATOR 112 MAY GENERATE A UNIQUE PUBLIC KEY FOR EACH DIGITAL TOKEN GENERATED BY TOKEN GENERATOR 112.

[0024] TOKEN GENERATOR 112 MAY ALSO PROMPT A USER, IN RESPONSE TO THE REQUEST TO GENERATE THE DIGITAL TOKEN, TO PROVIDE A SECOND PRIVATE KEY FOR USE IN ENCRYPTING INFORMATION ABOUT THE LOCATION AT WHICH THE ASSET CORRESPONDING TO THE DIGITAL TOKEN IS LOCATED. AS WITH THE FIRST PRIVATE KEY, THE SECOND PRIVATE KEY MAY BE USED IN CONJUNCTION WITH VARIOUS KEY GENERATION ALGORITHMS TO GENERATE A SECOND PUBLIC KEY THAT CAN BE USED TO ENCRYPT INFORMATION ABOUT THE LOCATION AT WHICH THE ASSET CORRESPONDING TO THE DIGITAL TOKEN IS LOCATED.

[0025] IN SOME ASPECTS, THE SECOND PRIVATE KEY MAY BE RETRIEVED FROM A PHYSICAL DEVICE ASSOCIATED WITH AN OWNER OF AN ASSET. TO OBTAIN THE SECOND PRIVATE KEY, TOKEN GENERATOR 112 MAY PROVIDE A PROMPT TO REQUEST THAT A USER SCAN OR OTHERWISE DIGITALLY READ OR INPUT A PHYSICAL IDENTIFIER FROM THE PHYSICAL DEVICE. THE PHYSICAL IDENTIFIER MAY BE SCANNED OR READ, VIA VARIOUS DATA CONNECTIONS BETWEEN THE PHYSICAL DEVICE AND A DEVICE USED TO INVOKE A TOKEN GENERATION PROCESS AT TOKEN GENERATOR 112 (E.G., A MOBILE PHONE, LAPTOP COMPUTER, DESKTOP COMPUTER, ETC.). FOR EXAMPLE, THE PHYSICAL IDENTIFIER MAY BE READ VIA A NEAR FIELD COMMUNICATION (NFC) DATA CONNECTION WITH THE PHYSICAL DEVICE ASSOCIATED WITH THE OWNER OF THE ASSET, READ FROM A RADIO FREQUENCY IDENTIFIER (RFID) MODULE (E.G., RFID TAG) EMBEDDED IN THE PHYSICAL DEVICE, VIA A BLUETOOTH® LOW ENERGY (BLE) CONNECTION WITH THE PHYSICAL DEVICE, OR OTHER

WIRED OR WIRELESS (E.G., CONTACTLESS) DATA CONNECTION BETWEEN THE PHYSICAL DEVICE AND THE DEVICE USED TO INVOKE THE TOKEN GENERATION PROCESS.

[0026] IN SOME ASPECTS, TOKEN GENERATOR 112 MAY ALLOW A USER TO MANUALLY ENTER AND/OR SELECT A PHYSICAL IDENTIFIER ASSOCIATED WITH THE PHYSICAL DEVICE. FOR EXAMPLE, TOKEN GENERATOR 112 CAN ALLOW A USER TO INPUT DATA SUCH AS A SERIAL NUMBER OF THE PHYSICAL DEVICE, AN IDENTIFIER OF A SUBSCRIBER IDENTIFICATION MODULE (SIM) ASSOCIATED WITH THE PHYSICAL DEVICE (E.G., AN INTEGRATED CIRCUIT CARD IDENTIFICATION (ICCID) NUMBER), AN INTERNATIONAL MOBILE EQUIPMENT IDENTITY (IMEI) ASSOCIATED WITH THE PHYSICAL DEVICE, AN IDENTIFIER OF AN RFID MODULE ASSOCIATED WITH THE PHYSICAL DEVICE, OR THE LIKE. IT SHOULD BE RECOGNIZED, HOWEVER, THAT THESE ARE MERELY EXAMPLES OF VARIOUS IDENTIFIERS THAT CAN BE PROVIDED AS A PHYSICAL IDENTIFIER, AND OTHER UNIQUE DEVICE IDENTIFIERS CAN ALSO OR ALTERNATIVELY BE PROVIDED AS THE SECOND PRIVATE KEY.

[0027] AFTER TOKEN GENERATOR 112 GENERATES THE FIRST PUBLIC KEY (WHICH CORRESPONDS TO THE FIRST PRIVATE KEY) AND THE SECOND PUBLIC KEY (WHICH CORRESPONDS TO THE SECOND PRIVATE KEY), THE DATA TO BE EMBEDDED IN THE DIGITAL TOKEN MAY BE ENCRYPTED. METADATA DESCRIBING THE DIGITAL TOKEN MAY BE ENCRYPTED USING THE FIRST PUBLIC KEY, AND THE LOCATION OF THE ASSET ASSOCIATED WITH THE DIGITAL TOKEN MAY BE ENCRYPTED USING THE SECOND PUBLIC KEY. THE METADATA DESCRIBING THE DIGITAL TOKEN MAY, FOR EXAMPLE, INCLUDE INFORMATION DEFINING VARIOUS ATTRIBUTES THAT DESCRIBE THE UNIQUE CHARACTER OF THE DIGITAL TOKEN AND THE UNDERLYING ASSET. FOR EXAMPLE, IN A SCENARIO WHERE A DIGITAL TOKEN CORRESPONDS TO A PLAYABLE CHARACTER IN A VIDEO GAME, THE METADATA DESCRIBING THE DIGITAL TOKEN MAY INCLUDE INFORMATION ABOUT THE APPEARANCE OF THE PLAYABLE CHARACTER, GAMEPLAY ATTRIBUTES FOR THE PLAYABLE CHARACTER, AN INVENTORY OF ITEMS THAT THE PLAYABLE CHARACTER CAN CARRY, AND THE LIKE. IN ANOTHER EXAMPLE, IN A SCENARIO WHERE A DIGITAL TOKEN CORRESPONDS TO A REPORT GENERATED FROM SENSITIVE (E.G., MARKET SENSITIVE) INFORMATION, THE METADATA DESCRIBING THE DIGITAL TOKEN MAY INCLUDE VARIOUS DATA POINTS DERIVED FROM THE SENSITIVE INFORMATION, SUCH AS ESG SCORE DATA DERIVED FROM SENSITIVE INFORMATION, INTERNAL EQUITY OR DEBT RATINGS DERIVED FROM MARKET SENSITIVE DATA, OR THE LIKE. MEANWHILE, THE LOCATION AT WHICH THE ASSET CORRESPONDING TO THE DIGITAL TOKEN IS LOCATED MAY BE ENCRYPTED USING THE SECOND PUBLIC KEY SO THAT EVEN IF THE FIRST PUBLIC KEY IS COMPROMISED, A MALICIOUS USER WOULD NOT PRACTICALLY BE ABLE TO OBTAIN, MODIFY, AND/OR TRANSFER THE UNDERLYING ASSET ASSOCIATED WITH THE DIGITAL TOKEN.

[0028] AFTER ENCRYPTING THE METADATA AND THE LOCATION (OR ADDRESS) OF THE UNDERLYING ASSET ASSOCIATED WITH THE DIGITAL TOKEN, TOKEN GENERATOR 112 CAN MINT THE DIGITAL TOKEN ON THE BLOCKCHAIN. THE DIGITAL TOKEN GENERALLY INCLUDES THE ENCRYPTED METADATA AND THE ENCRYPTED ADDRESS. IN MINTING THE DIGITAL TOKEN, TOKEN GENERATOR 112 CAN INVOKE A SMART CONTRACT ON BLOCKCHAIN 122 TO CREATE THE DIGITAL TOKEN AND CONCURRENTLY GENERATE A RECORD EVIDENCING THE CREATION OF THE DIGITAL TOKEN ON THE BLOCKCHAIN AND INITIAL OWNERSHIP OF THE DIGITAL TOKEN BY THE WALLET OWNER WHOSE PRIVATE KEY CAN BE USED TO DECRYPT THE DIGITAL TOKEN. IN MINTING THE DIGITAL TOKEN ON BLOCKCHAIN 122, THE DIGITAL TOKEN MAY BE STORED ON

THE BLOCKCHAIN 122, AND THE UNDERLYING ASSETS ASSOCIATED WITH THE DIGITAL TOKEN MAY BE MAINTAINED IN A SEPARATE LOCATION FROM THE BLOCKCHAIN 122.

[0029] TOKEN RETRIEVER 114 GENERALLY ALLOWS A USER TO VIEW A PREVIOUSLY MINTED DIGITAL TOKEN. TO PROVIDE A DIGITAL TOKEN TO THE USER FOR VIEWING, TOKEN RETRIEVER 114 MAY REQUEST AN IDENTIFIER OF THE DIGITAL TOKEN AND RETRIEVE THE DIGITAL TOKEN FROM BLOCKCHAIN 124. THE RETRIEVED DIGITAL TOKEN MAY INCLUDE THE ENCRYPTED LOCATION AT WHICH THE UNDERLYING ASSET IS LOCATED AND THE ENCRYPTED METADATA, WHICH, AS DISCUSSED ABOVE, MAY BE ENCRYPTED USING DIFFERENT KEYS TO PROVIDE FOR THE SECURITY OF THE METADATA IN THE DIGITAL TOKEN AND THE LOCATION AT WHICH THE UNDERLYING ASSET IS STORED.

[0030] TO ALLOW A USER TO VIEW THE UNDERLYING ASSET ASSOCIATED WITH THE DIGITAL TOKEN, TOKEN RETRIEVER 114 CAN REQUEST THE SECOND PRIVATE KEY FROM THE USER. UPON RECEIPT OF THE SECOND PRIVATE KEY (WHICH, AS DISCUSSED ABOVE, MAY BE READ VIA A WIRED OR WIRELESS CONNECTION WITH THE PHYSICAL DEVICE ASSOCIATED WITH THE OWNER OF THE ASSET OR MAY BE MANUALLY ENTERED), TOKEN RETRIEVER 114 CAN DECRYPT THE LOCATION OF THE UNDERLYING ASSET AND PROVIDE THE LOCATION OF THE UNDERLYING ASSET TO THE USER VIEWING THE DIGITAL TOKEN. THE METADATA MAY ALSO BE PROVIDED TO THE VIEWER IN AN ENCRYPTED FORM, AND THE USER CAN DECRYPT THE METADATA USING THE FIRST PRIVATE KEY. GENERALLY, THE DATA INCLUDED IN OR ASSOCIATED WITH A DIGITAL TOKEN MAY BE TRANSMITTED FROM TOKEN PROCESSING SYSTEM 110 TO A CLIENT DEVICE (NOT PICTURED) IN AN ENCRYPTED FORMAT AND DECRYPTED LOCALLY (AT THE CLIENT DEVICE) SO THAT DECRYPTED DATA IS NOT AT RISK OF EXFILTRATION WHILE IN TRANSIT. IN SOME ASPECTS, THE KEYS NEEDED TO DECRYPT THE LOCATION DATA IN THE DIGITAL TOKEN AND THE METADATA IN THE DIGITAL TOKEN MAY BE PROVIDED TO TOKEN RETRIEVER 114 FROM A CLIENT DEVICE VIA VARIOUS KEY EXCHANGE MECHANISMS, AND THE DIGITAL TOKEN MAY BE DECRYPTED. THE DECRYPTED DIGITAL TOKEN MAY THEN BE RE-ENCRYPTED USING A DIFFERENT (MUTUALLY AGREED UPON) SET OF KEYS, WHICH MAY ALLOW FOR THE INFORMATION IN THE DIGITAL TOKEN TO BE SECURED WHILE IN TRANSIT.

[0031] TOKEN TRANSFEROR 116 GENERALLY FACILITATES THE ON-CHAIN TRANSFER OF DIGITAL TOKENS AND THE UNDERLYING ASSETS FROM AN INITIAL OWNER TO A SUBSEQUENT OWNER. TO TRANSFER A DIGITAL TOKEN (AND THE UNDERLYING ASSET), THE TRANSFEROR CAN VIEW AND UNLOCK THE DIGITAL TOKEN VIA TOKEN RETRIEVER 114 AND INITIATE THE TRANSFER PROCESS. TOKEN TRANSFEROR 116 CAN THEN REQUEST A SET OF KEYS ASSOCIATED WITH THE TRANSFEREE (E.G., THE USER TO WHOM OWNERSHIP OF THE DIGITAL TOKEN AND THE UNDERLYING ASSET IS TO BE TRANSFERRED) FOR USE IN ENCRYPTING THE METADATA AND THE LOCATION INFORMATION IN THE DIGITAL TOKEN. THE REQUESTED SET OF KEYS MAY, IN SOME ASPECTS, INCLUDE A PUBLIC KEY ASSOCIATED WITH THE WALLET INTO WHICH THE DIGITAL TOKEN IS TO BE TRANSFERRED AND A PUBLIC KEY ASSOCIATED WITH A PHYSICAL DEVICE OWNED BY THE TRANSFEREE. AFTER RECEIVING THE REQUESTED SET OF KEYS, TOKEN TRANSFEROR 116 CAN ENCRYPT THE METADATA USING THE PUBLIC KEY ASSOCIATED WITH THE WALLET INTO WHICH THE DIGITAL TOKEN IS TO BE TRANSFERRED AND CAN ENCRYPT THE LOCATION OF THE UNDERLYING ASSET USING THE PUBLIC KEY ASSOCIATED WITH THE PHYSICAL DEVICE OWNED BY THE TRANSFEREE. SUBSEQUENTLY, THE UPDATED TOKEN - WHICH IS NOW READABLE BY ANYONE WHO HAS THE TRANSFEREE'S PRIVATE

KEYS, BUT UNREADABLE BY THE PREVIOUS OWNER -MAY BE PERSISTED TO BLOCKCHAIN 122 TO EVIDENCE THE TRANSFER OF OWNERSHIP.

[0032] IN SOME ASPECTS, TOKEN TRANSFEROR 116 MAY FUNCTION AS AN INTERMEDIARY TO COORDINATE THE TRANSFER OF A DIGITAL TOKEN AND THE UNDERLYING ASSETS FROM A CURRENT OWNER (THE TRANSFEROR) TO A NEW OWNER (THE TRANSFEREE). IN SUCH A CASE, TOKEN TRANSFEROR 116 MAY RECEIVE INFORMATION IDENTIFYING THE TRANSFEROR AND TRANSFEREE AND INITIATE THE PROCESS TO OBTAIN THE APPROPRIATE ENCRYPTION AND DECRYPTION KEYS SEPARATELY. FOR EXAMPLE, TOKEN TRANSFEROR 116 MAY REQUEST THE PRIVATE KEYS FROM THE CURRENT OWNER OF THE DIGITAL TOKEN SEPARATELY FROM REQUESTING THE PUBLIC KEYS FROM THE NEW OWNER OF THE DIGITAL TOKEN. BY SEPARATELY REQUESTING THESE KEYS, TOKEN TRANSFEROR 116 MAY PREVENT THE NEW OWNER OF THE DIGITAL ASSET FROM OBTAINING THE CURRENT OWNER'S PRIVATE KEYS AND THUS MAY PREVENT THE CURRENT OWNER'S OTHER DIGITAL TOKENS FROM BEING COMPROMISED BY THE NEW OWNER. FURTHER, THE CURRENT OWNER OF THE DIGITAL TOKEN MAY NOT HAVE ACCESS TO THE NEW OWNER'S PUBLIC KEYS, WHICH MAY PREVENT THE CURRENT OWNER OF THE DIGITAL TOKEN FROM CREATING NEW TOKENS USING THE NEW OWNER'S PUBLIC KEYS.

EXAMPLE PIPELINE FOR GENERATING DIGITAL TOKENS ON A BLOCKCHAIN BASED ON PHYSICAL DEVICE IDENTIFIERS

[0033] FIG. 2 ILLUSTRATES AN EXAMPLE PIPELINE 200 FOR GENERATING DIGITAL TOKENS ON A BLOCKCHAIN, ACCORDING TO ASPECTS OF THE PRESENT DISCLOSURE.

[0034] AS ILLUSTRATED, PIPELINE 200 BEGINS WITH WALLET KEY ENTRY STAGE 210. AT WALLET KEY ENTRY STAGE 210, THE USER WHO IS CREATING A DIGITAL TOKEN CORRESPONDING TO AN ASSET PROVIDES A PRIVATE KEY ASSOCIATED WITH THE WALLET INTO WHICH THE DIGITAL TOKEN IS TO BE DEPOSITED. A TOKEN GENERATOR (E.G., TOKEN GENERATOR 112 ILLUSTRATED IN FIG. 1) CAN PROMPT THE USER FOR A PRIVATE KEY, WHICH THE USER MAY PROVIDE BY TYPING IN THE PRIVATE KEY, SCANNING A PHYSICAL DEVICE ON WHICH THE PRIVATE KEY IS STORED, OR THE LIKE. AFTER THE TOKEN GENERATOR RECEIVES THE PRIVATE KEY ASSOCIATED WITH THE WALLET INTO WHICH THE DIGITAL TOKEN IS TO BE DEPOSITED, THE TOKEN GENERATOR CAN GENERATE THE PUBLIC KEY (E.G., AN ENCRYPTION KEY) USING VARIOUS KEY GENERATION MECHANISMS THAT CAN GENERATE A PUBLIC KEY FROM A PRIVATE KEY.

[0035] PIPELINE 200 MAY PROCEED TO PHYSICAL IDENTIFIER ENTRY STAGE 220. AT PHYSICAL IDENTIFIER ENTRY STAGE 220, THE TOKEN GENERATOR CAN REQUEST A PHYSICAL IDENTIFIER OF A PHYSICAL DEVICE OWNED BY THE OWNER OF THE DIGITAL TOKEN AND THE UNDERLYING ASSET FOR USE IN GENERATING THE DIGITAL TOKEN. A PUBLIC KEY ASSOCIATED WITH THE PHYSICAL DEVICE MAY BE DERIVED FROM THE PHYSICAL IDENTIFIER USING VARIOUS KEY GENERATION MECHANISMS, TREATING THE PHYSICAL IDENTIFIER AS THE PRIVATE KEY THAT CAN BE USED TO DECRYPT DATA ENCRYPTED USING THE PUBLIC KEY DERIVED FROM THE PHYSICAL IDENTIFIER. THE PHYSICAL IDENTIFIER MAY BE PROVIDED, FOR EXAMPLE, VIA READING THE IDENTIFIER FROM THE PHYSICAL DEVICE USING A WIRED OR WIRELESS DATA CONNECTION OR VIA MANUAL ENTRY OF THE IDENTIFIER. AS DISCUSSED,

THE IDENTIFIER MAY BE READ FROM VARIOUS SHORT-RANGE DATA CONNECTIONS SUCH AS AN NFC CONNECTION, VIA READING AN RFID TAG, VIA A BLE CONNECTION, OR THE LIKE. IN SOME ASPECTS, THE IDENTIFIER MAY BE AN IDENTIFIER ASSOCIATED WITH A SIM (E.G., AN ICCID NUMBER), A SERIAL NUMBER ASSOCIATED WITH THE PHYSICAL DEVICE, OR THE LIKE. IT SHOULD BE NOTED THAT THE PHYSICAL IDENTIFIER MAY BE ANY SORT OF GLOBALLY UNIQUE IDENTIFIER THAT UNIQUELY IDENTIFIES A PHYSICAL DEVICE OWNED BY THE OWNER OF THE ASSET AND DIGITAL TOKEN.

[0036] AT METADATA ENCRYPTION STAGE 230, THE TOKEN GENERATOR ENCRYPTS THE METADATA CARRIED IN THE DIGITAL TOKEN. AS DISCUSSED, THE METADATA MAY BE ENCRYPTED USING THE PUBLIC KEY DERIVED FROM OR OTHERWISE ASSOCIATED WITH THE PRIVATE KEY OF THE DIGITAL WALLET.

[0037] AT THE ASSET ADDRESS ENCRYPTION STAGE 240, THE LOCATION (OR ADDRESS) OF THE ASSET CORRESPONDING TO THE DIGITAL KEY IS ENCRYPTED. AS DISCUSSED, THE LOCATION (OR ADDRESS) MAY BE ENCRYPTED USING THE PUBLIC KEY DERIVED FROM THE PHYSICAL IDENTIFIER.

[0038] AT TOKEN OWNERSHIP ASSIGNMENT STAGE 250, A RECORD INDICATING OWNERSHIP OF THE TOKEN MAY BE GENERATED.

[0039] FINALLY, AT TOKEN MINTING STAGE 260, THE DIGITAL TOKEN IS MINTED AND PERSISTED TO A BLOCKCHAIN. THE DIGITAL TOKEN MAY BE MINTED USING THE ENCRYPTED METADATA AND THE ENCRYPTED ADDRESS INFORMATION SO THAT MULTIPLE KEYS ARE NEEDED TO DECRYPT THE CONTENT OF THE DIGITAL TOKEN AND ACCESS THE UNDERLYING ASSET CORRESPONDING TO THE DIGITAL TOKEN. AT TOKEN MINTING STAGE 260, THE DIGITAL TOKEN MAY BE MINTED BY INVOKING ONE OR MORE SMART CONTRACTS ON A BLOCKCHAIN (E.G., BLOCKCHAIN 122 ILLUSTRATED IN FIG. 1) THAT CAUSE A RECORD TO BE GENERATED ON THE BLOCKCHAIN EVIDENCING THE CREATION OF THE DIGITAL TOKEN AND INITIAL ASSIGNMENT OF OWNERSHIP OF THE DIGITAL TOKEN TO THE OWNER WHOSE WALLET PRIVATE KEY WAS PROVIDED AT WALLET KEY ENTRY STAGE 210. THE DIGITAL TOKEN MINTED AND STORED ON BLOCKCHAIN 122 MAY SUBSEQUENTLY BE RETRIEVED AND TRANSFERRED, AS DISCUSSED ABOVE, USING THE PRIVATE KEY ASSOCIATED WITH THE OWNER'S WALLET AND THE PHYSICAL IDENTIFIER OF THE OWNER'S PHYSICAL DEVICE.

[0040] FIG. 3 ILLUSTRATES EXAMPLE OPERATIONS 300 FOR GENERATING DIGITAL TOKENS CORRESPONDING TO OTHER PHYSICAL OR DIGITAL ASSETS BASED ON PHYSICAL DEVICE IDENTIFIERS, ACCORDING TO ASPECTS OF THE PRESENT DISCLOSURE. THE OPERATIONS DESCRIBED HEREIN MAY BE PERFORMED, FOR EXAMPLE, BY TOKEN GENERATOR 112 ILLUSTRATED IN FIG. 1.

[0041] AS ILLUSTRATED, OPERATIONS 300 MAY BEGIN AT BLOCK 310, WHERE A REQUEST TO CREATE A DIGITAL TOKEN CORRESPONDING TO AN ASSET IS RECEIVED (E.G., AT A TOKEN GENERATOR, SUCH AS TOKEN GENERATOR 112 ILLUSTRATED IN FIG. 1). GENERALLY, THE REQUEST TO CREATE THE DIGITAL ASSET MAY INCLUDE INFORMATION IDENTIFYING A LOCATION AT WHICH THE CORRESPONDING ASSET IS STORED, SUCH AS A URL OR URI FOR DIGITAL ASSETS OR A PHYSICAL LOCATION AND ACCESS INFORMATION FOR A PHYSICAL ASSET. THE CORRESPONDING ASSET MAY BE A DIGITAL ASSET, SUCH AS A DOCUMENT OR REPOSITORY OF SENSITIVE INFORMATION, DIGITAL ARTWORK, OR THE LIKE,

A DIGITAL COUNTERPART OF A PHYSICAL ASSET, SUCH AS A DIGITAL CERTIFICATE ASSOCIATED WITH A PHYSICAL ASSET, OR A PHYSICAL ASSET ITSELF.

[0042] AT BLOCK 320, A FIRST PRIVATE KEY IS RECEIVED (E.G., AT A TOKEN GENERATOR, SUCH AS TOKEN GENERATOR 112 ILLUSTRATED IN FIG. 1). BLOCK 320 MAY CORRESPOND TO WALLET KEY ENTRY STAGE 210 ILLUSTRATED IN FIG. 2. THE FIRST PRIVATE KEY MAY BE ASSOCIATED WITH A WALLET IN WHICH THE DIGITAL TOKEN IS TO BE STORED. A TOKEN GENERATOR CAN USE VARIOUS KEY GENERATION MECHANISMS TO GENERATE A FIRST PUBLIC KEY WHICH MAY BE USED TO ENCRYPT DATA THAT CAN THEN BE DECRYPTED USING THE FIRST PRIVATE KEY.

[0043] AT BLOCK 330, A SECOND PRIVATE KEY IS RECEIVED (E.G., AT A TOKEN GENERATOR, SUCH AS TOKEN GENERATOR 112 ILLUSTRATED IN FIG. 1). BLOCK 330 MAY CORRESPOND TO PHYSICAL IDENTIFIER ENTRY STAGE 220 ILLUSTRATED IN FIG. 2. THE SECOND PRIVATE KEY MAY BE RECEIVED FROM A PHYSICAL DEVICE ASSOCIATED WITH AN OWNER OF THE ASSET.

[0044] IN SOME ASPECTS, THE SECOND PRIVATE KEY MAY BE RECEIVED VIA SCANNING OR OTHERWISE READING DATA FROM THE PHYSICAL DEVICE ASSOCIATED WITH THE OWNER OF THE ASSET VIA A WIRED OR WIRELESS CONNECTION. A WIRELESS CONNECTION BY WHICH THE SECOND PRIVATE KEY MAY BE RECEIVED MAY INCLUDE, FOR EXAMPLE, AN NFC CONNECTION, A CONNECTION GENERATED BY A RFID TAG, A BLE CONNECTION, OR THE LIKE. ALTERNATIVELY, THE SECOND PRIVATE KEY MAY BE MANUALLY ENTERED INTO A DATA ENTRY FORM AND PROVIDED TO THE TOKEN GENERATOR.

[0045] THE PRIVATE KEY MAY INCLUDE VARIOUS PHYSICAL IDENTIFIERS ASSOCIATED WITH THE PHYSICAL DEVICE. FOR EXAMPLE, A PHYSICAL IDENTIFIER MAY INCLUDE AN IDENTIFIER OF AN NFC CHIP ON THE PHYSICAL DEVICE, AN IDENTIFIER OF AN RFID TAG ON THE PHYSICAL DEVICE, OR THE LIKE. IN ANOTHER EXAMPLE, THE PHYSICAL IDENTIFIER MAY BE VARIOUS IDENTIFIERS ASSOCIATED WITH A MOBILE DEVICE (E.G., A CELLULAR PHONE) THROUGH WHICH THE DIGITAL TOKEN IS BEING CREATED. THESE IDENTIFIERS MAY INCLUDE A SERIAL NUMBER OF THE PHYSICAL DEVICE, AN ICCID NUMBER OR OTHER IDENTIFIER OF THE SIM INSTALLED IN THE PHYSICAL DEVICE, AN IMEI ASSOCIATED WITH THE PHYSICAL DEVICE, OR OTHER GLOBALLY UNIQUE IDENTIFIER.

[0046] AT BLOCK 340, AN ADDRESS OF THE ASSET IS ENCRYPTED WITH A PUBLIC KEY ASSOCIATED WITH THE SECOND PRIVATE KEY (E.G., AT A TOKEN GENERATOR, SUCH AS TOKEN GENERATOR 112 ILLUSTRATED IN FIG. 1). BLOCK 340 MAY CORRESPOND TO ASSET ADDRESS ENCRYPTION STAGE 240 ILLUSTRATED IN FIG. 2.

[0047] AT BLOCK 350, METADATA ASSOCIATED WITH THE DIGITAL TOKEN IS ENCRYPTED WITH A PUBLIC KEY ASSOCIATED WITH THE FIRST PRIVATE KEY (E.G., AT A TOKEN GENERATOR, SUCH AS TOKEN GENERATOR 112 ILLUSTRATED IN FIG. 1). BLOCK 350 MAY CORRESPOND TO METADATA ENCRYPTION STAGE 230 ILLUSTRATED IN FIG. 2.

[0048] AT BLOCK 360, THE DIGITAL TOKEN IS MINTED ON A BLOCKCHAIN. THE DIGITAL TOKEN MAY BE MINTED BASED ON THE ENCRYPTED ADDRESS OF THE ASSET AND THE ENCRYPTED METADATA. IN SOME EXAMPLES, WHERE THE DIGITAL TOKEN CONFORMS TO THE ETHEREUM REQUEST FOR COMMENTS 1155 (ERC-1155) STANDARD, THE ENCRYPTED ADDRESS

OF THE ASSET MAY BE STORED IN THE TOKEN URI FIELD, AND THE ENCRYPTED METADATA MAY BE STORED IN VARIOUS METADATA FIELDS IN THE DIGITAL TOKEN.

[0049] THE DIGITAL TOKEN MAY BE, IN SOME ASPECTS, AN NFT HAVING OWNERSHIP RECORDS MAINTAINED ON A BLOCKCHAIN. IN SUCH A CASE, THE DIGITAL TOKEN MAY REPRESENT A SPECIFIC ASSET AND MAY NOT BE INTERCHANGEABLE WITH OTHER DIGITAL TOKENS REPRESENTING OTHER ASSETS.

[0050] IN SOME ASPECTS, AFTER THE DIGITAL TOKEN IS MINTED ON THE BLOCKCHAIN, THE DIGITAL TOKEN MAY BE COMMITTED TO THE WALLET. IN COMMITTING THE DIGITAL TOKEN TO THE WALLET, A REFERENCE TO THE DIGITAL TOKEN MAY BE WRITTEN TO THE WALLET. THE REFERENCE TO THE DIGITAL TOKEN MAY IDENTIFY A LOCATION IN THE BLOCKCHAIN (OR IN SOME OTHER STORAGE NETWORK) AT WHICH THE DIGITAL TOKEN MAY BE LOCATED, AND THE OWNER OF THE WALLET CAN USE THIS INFORMATION TO ACCESS THE DIGITAL TOKEN, VIEW THE METADATA STORED IN THE DIGITAL TOKEN, ACCESS THE LOCATION OF THE ASSET ASSOCIATED WITH THE DIGITAL TOKEN, AND SO ON.

[0051] AS DISCUSSED, BECAUSE THE ENCRYPTED ADDRESS OF THE ASSET AND THE ENCRYPTED METADATA ARE ENCRYPTED USING DIFFERENT KEYS, COMPROMISING ONE KEY MAY NOT ALLOW A MALICIOUS USER TO OBTAIN A USABLE VERSION OF THE DIGITAL TOKEN AND THE UNDERLYING ASSET ASSOCIATED WITH THE DIGITAL TOKEN. FURTHER, BECAUSE DIFFERENT KEYS ARE USED TO SEPARATELY ENCRYPT DATA STORED IN A DIGITAL TOKEN, ADDITIONAL COMPUTATIONAL COMPLEXITY MAY BE INTRODUCED INTO ATTEMPTS TO DECRYPT THE DIGITAL TOKEN.

[0052] FOR EXAMPLE, ASSUME THAT DIFFERENT 128 BIT KEYS ARE USED TO ENCRYPT THE METADATA AND THE ADDRESS OF THE ASSET. IN SUCH A CASE, THE DIGITAL TOKEN MAY BE BROKEN BY DECRYPTING THE METADATA USING 2128 KEYS AND SEPARATELY DECRYPTING THE ADDRESS OF THE UNDERLYING ASSET USING 2128 KEYS. EVEN IF ONE KEY IS COMPROMISED, DECRYPTING THE DATA ENCRYPTED USING THE OTHER KEY MAY NECESSITATE 2128 DECRYPTION OPERATIONS IN A BRUTE FORCE ATTACK, WHICH MAY BE A COMPUTATIONALLY IMPOSSIBLE PROBLEM TO SOLVE IN A REASONABLE AMOUNT OF TIME.

[0053] IN SOME ASPECTS, THE METADATA ASSOCIATED WITH THE DIGITAL TOKEN MAY INCLUDE A URI IDENTIFYING A LOCATION AT WHICH THE DIGITAL ASSET IS STORED.

[0054] IN SOME ASPECTS, THE METADATA ASSOCIATED WITH THE DIGITAL TOKEN MAY INCLUDE PRIVATE DATA USED TO GENERATE PUBLIC DATA STORED IN THE DIGITAL ASSET.

[0055] IN SOME ASPECTS, THE METADATA ASSOCIATED WITH THE DIGITAL TOKEN MAY INCLUDE PUBLIC DATA GENERATED FROM PRIVATE DATA STORED IN THE DIGITAL ASSET.

[0056] IN SOME ASPECTS, TO VIEW THE DIGITAL ASSET, A REQUEST TO VIEW THE DIGITAL ASSET MAY BE RECEIVED, ALONG WITH THE SECOND PRIVATE KEY. THE DIGITAL TOKEN MAY BE RETRIEVED (E.G., FROM THE BLOCKCHAIN), AND THE ENCRYPTED ADDRESS IN THE DIGITAL TOKEN MAY BE DECRYPTED USING THE SECOND PRIVATE KEY. THE DECRYPTED ADDRESS OF THE ASSET CORRESPONDING TO THE DIGITAL TOKEN AND THE ENCRYPTED METADATA IN THE DIGITAL TOKEN MAY BE RETURNED. THE ENCRYPTED METADATA IN THE DIGITAL TOKEN MAY BE DECRYPTABLE USING THE FIRST PRIVATE KEY.

[0057] IN SOME ASPECTS, A REQUEST TO TRANSFER THE DIGITAL TOKEN FROM THE WALLET TO A SECOND WALLET MAY BE RECEIVED. A PUBLIC KEY ASSOCIATED WITH THE SECOND WALLET AND A PUBLIC KEY OF THE SECOND PHYSICAL DEVICE TO BE ASSOCIATED WITH THE DIGITAL TOKEN MAY BE REQUESTED. BASED ON THE FIRST PRIVATE KEY, THE SECOND PRIVATE KEY, THE PUBLIC KEY ASSOCIATED WITH THE SECOND WALLET, AND THE PUBLIC KEY OF THE SECOND PHYSICAL DEVICE, OWNERSHIP OF THE DIGITAL TOKEN IS TRANSFERRED TO A USER ASSOCIATED WITH THE SECOND WALLET. TO TRANSFER OWNERSHIP, THE DIGITAL TOKEN MAY BE DECRYPTED USING THE FIRST PRIVATE KEY AND THE SECOND PRIVATE KEY, AND THEN RE-ENCRYPTED USING THE PUBLIC KEY ASSOCIATED WITH THE SECOND WALLET AND THE PUBLIC KEY OF THE SECOND PHYSICAL DEVICE. A NEW RECORD MAY SUBSEQUENTLY BE WRITTEN TO THE BLOCKCHAIN EVIDENCING THE TRANSFER OF THE DIGITAL TOKEN TO THE OWNER OF THE SECOND WALLET. FURTHER, BECAUSE THE DIGITAL TOKEN HAS BEEN RE-ENCRYPTED USING A NEW SET OF KEYS, THE PREVIOUS OWNER OF THE DIGITAL TOKEN MAY NO LONGER BE ABLE TO DECRYPT AND VIEW THE METADATA IN THE DIGITAL TOKEN AND THE ADDRESS AT WHICH THE ASSET ASSOCIATED WITH THE TOKEN IS LOCATED.

EXAMPLE SYSTEM FOR GENERATING AND MAINTAINING DIGITAL TOKENS BASED ON PHYSICAL DEVICE

IDENTIFIERS

[0058] FIG. 4 ILLUSTRATES AN EXAMPLE SYSTEM 400 CONFIGURED TO PERFORM THE METHODS DESCRIBED HEREIN, INCLUDING, FOR EXAMPLE, OPERATIONS 300 OF FIG. 3. IN SOME EMBODIMENTS, SYSTEM 400 MAY ACT AS A TOKEN PROCESSING SYSTEM, SUCH AS TOKEN PROCESSING SYSTEM 110 ILLUSTRATED IN FIG. 1.

[0059] AS SHOWN, SYSTEM 400 INCLUDES A CENTRAL PROCESSING UNIT (CPU) 402, ONE OR MORE I/O DEVICE INTERFACES 404 THAT MAY ALLOW FOR THE CONNECTION OF VARIOUS I/O DEVICES 414 (E.G., KEYBOARDS, DISPLAYS, MOUSE DEVICES, PEN INPUT, ETC.) TO THE SYSTEM 400, NETWORK INTERFACE 406 THROUGH WHICH SYSTEM 400 IS CONNECTED TO A NETWORK (WHICH MAY BE A LOCAL NETWORK, AN INTRANET, THE INTERNET, OR ANY OTHER GROUP OF COMPUTING DEVICES COMMUNICATIVELY CONNECTED TO EACH OTHER), A MEMORY 408, AND AN INTERCONNECT 412. THE I/O DEVICES 414 AND/OR NETWORK INTERFACE 406 MAY BE USED TO RECEIVE REQUESTS TO GENERATE, RETRIEVE, AND TRANSFER DIGITAL TOKENS ON A BLOCKCHAIN.

[0060] CPU 402 MAY RETRIEVE AND EXECUTE PROGRAMMING INSTRUCTIONS STORED IN THE MEMORY 408. SIMILARLY, THE CPU 402 MAY RETRIEVE AND STORE APPLICATION DATA RESIDING IN THE MEMORY 408. THE INTERCONNECT 412 TRANSMITS PROGRAMMING INSTRUCTIONS AND APPLICATION DATA, AMONG THE CPU 402, I/O DEVICE INTERFACE 404, NETWORK INTERFACE 406, AND MEMORY 408.

[0061] CPU 402 IS INCLUDED TO BE REPRESENTATIVE OF A SINGLE CPU, MULTIPLE CPUS, A SINGLE CPU HAVING MULTIPLE PROCESSING CORES, AND THE LIKE.

[0062] MEMORY 408 IS REPRESENTATIVE OF A VOLATILE MEMORY, SUCH AS A RANDOM ACCESS MEMORY, OR A NONVOLATILE MEMORY, SUCH AS NONVOLATILE RANDOM ACCESS MEMORY, PHASE CHANGE RANDOM ACCESS MEMORY, OR THE LIKE. AS SHOWN, MEMORY 408 INCLUDES A TOKEN GENERATOR 420, TOKEN RETRIEVER 430, AND TOKEN TRANSFEROR 440, AND KEY DATA STORE 450.

[0063] TOKEN GENERATOR 420 MAY CORRESPOND TO TOKEN GENERATOR 112 ILLUSTRATED IN FIG. 1 AND ALLOW FOR THE GENERATION OF DIGITAL TOKENS CORRESPONDING TO OTHER ASSETS USING A FIRST PRIVATE KEY AND A SECOND PRIVATE KEY. TOKEN GENERATOR 420 MAY RECEIVE A FIRST PRIVATE KEY, WHICH MAY BE A PRIVATE KEY ASSOCIATED WITH A WALLET IN WHICH A DIGITAL TOKEN IS TO BE DEPOSITED, AND A SECOND PRIVATE KEY, WHICH MAY BE A PHYSICAL IDENTIFIER OF A PHYSICAL DEVICE OWNED BY THE OWNER OF THE DIGITAL TOKEN AND THE UNDERLYING ASSET FOR WHICH THE DIGITAL TOKEN IS TO BE GENERATED.

[0064] IN SOME ASPECTS, THE SECOND PRIVATE KEY MAY BE OBTAINED BY READING THE PHYSICAL IDENTIFIER OF THE PHYSICAL DEVICE VIA A PHYSICAL DEVICE IDENTIFIER READER 410 AND ITS ASSOCIATED ANTENNA 416, WHICH MAY ALLOW SYSTEM 400 TO WIRELESSLY READ DATA VIA AN NFC CONNECTION WITH THE PHYSICAL DEVICE, WIRELESSLY READ DATA STORED ON AN RFID TAG, WIRELESS READ DATA VIA A BLE CONNECTION WITH THE PHYSICAL DEVICE, OR THE LIKE. IN SOME ASPECTS, THE SECOND PRIVATE KEY MAY BE OBTAINED VIA MANUAL ENTRY OF THE PHYSICAL IDENTIFIER OF THE PHYSICAL DEVICE THROUGH AN I/O DEVICE 414 VIA I/O DEVICE INTERFACE 404.

[0065] PUBLIC KEYS MAY BE DERIVED FROM THE FIRST KEY AND SECOND KEY, AND TOKEN GENERATOR 420 CAN USE THE PUBLIC KEYS TO SEPARATELY ENCRYPT THE METADATA FOR THE DIGITAL TOKEN AND THE LOCATION AT WHICH THE UNDERLYING ASSET MAY BE ACCESSED. THE DIGITAL TOKEN, INCLUDING THE SEPARATELY ENCRYPTED METADATA AND LOCATION INFORMATION, MAY BE MINTED, AND A RECORD MAY BE COMMITTED TO A BLOCKCHAIN ON AN EXTERNAL NETWORK, VIA NETWORK INTERFACE 406, EVIDENCING THE CREATION OF THE DIGITAL TOKEN AND INITIAL OWNERSHIP OF THE DIGITAL TOKEN AND THE UNDERLYING ASSET BY THE OWNER OF THE WALLET.

[0066] TOKEN RETRIEVER 430 MAY CORRESPOND TO TOKEN RETRIEVER 114 ILLUSTRATED IN FIG. 1. GENERALLY, TOKEN RETRIEVER 430 MAY ALLOW FOR THE OWNER OF A DIGITAL TOKEN OR DESIGNED PERSONS HAVING BOTH THE FIRST AND SECOND PRIVATE KEYS TO RETRIEVE THE DIGITAL TOKEN AND DECRYPT THE LOCATION INFORMATION AND METADATA STORED IN THE DIGITAL TOKEN. ENCRYPTED INFORMATION MAY REMAIN ENCRYPTED WHILE IN TRANSIT FROM TOKEN RETRIEVER 430 TO A REMOTE CLIENT DEVICE (E.G., VIA NETWORK INTERFACE 406) SO THAT THE SECURITY OF THE DATA STORED IN THE DIGITAL TOKEN MAY BE MAINTAINED.

[0067] TOKEN TRANSFEROR 440 MAY CORRESPOND TO TOKEN TRANSFEROR 116 ILLUSTRATED IN FIG. 1 AND MAY ALLOW THE OWNER OF A DIGITAL TOKEN AND THE UNDERLYING ASSET TO TRANSFER OWNERSHIP OF THE DIGITAL TOKEN AND UNDERLYING ASSET TO A TRANSFEREE, OR NEW OWNER. TO DO SO, TOKEN TRANSFEROR 440 MAY REQUEST THE PRIVATE KEYS OF THE TRANSFEROR AND THE PUBLIC KEYS OF THE TRANSFEREE. THE PRIVATE KEYS OF THE TRANSFEROR (E.G., THE PRIVATE KEY FOR THE TRANSFEROR'S

WALLET AND THE PHYSICAL IDENTIFIER OF THE TRANSFEROR'S PHYSICAL DEVICE) MAY BE USED TO DECRYPT THE METADATA AND THE ADDRESS INFORMATION FOR THE UNDERLYING ASSET, AND THE PUBLIC KEYS OF THE TRANSFEREE MAY BE USED TO RE-ENCRYPT THE METADATA AND ADDRESS INFORMATION FOR THE UNDERLYING ASSET. TOKEN TRANSFEROR 440 MAY THEN GENERATE A RECORD FOR COMMITMENT TO A BLOCKCHAIN ON AN EXTERNAL NETWORK, VIA NETWORK INTERFACE 406, EVIDENCING THE TRANSFER OF OWNERSHIP OF THE DIGITAL TOKEN FROM THE TRANSFEROR TO THE TRANSFEREE.

[0068] IN SOME ASPECTS, THE FIRST PRIVATE KEY MAY BE STORED IN A KEY DATA STORE 450 IN MEMORY 408. KEY DATA STORE 450 MAY ALLOW FOR VARIOUS ENCRYPTION AND/OR DECRYPTION KEYS (E.G., PUBLIC AND/OR PRIVATE KEYS) TO BE SECURELY MAINTAINED ON SYSTEM 400 FOR USE BY TOKEN GENERATOR 420 TO ENCRYPT THE METADATA IN A DIGITAL TOKEN AND FOR USE BY TOKEN RETRIEVER 430 AND TOKEN TRANSFEROR 440 TO DECRYPT THE METADATA IN THE DIGITAL TOKEN. TO PROVIDE FOR ADDITIONAL SECURITY, THE SECOND PRIVATE KEY AND THE SECOND PUBLIC KEY MAY NOT BE STORED IN KEY DATA STORE 450 TO REQUIRE PRESENTATION OF THE SECOND PRIVATE KEY AND THE SECOND PUBLIC KEY FOR GENERATION, VIEWING, AND TRANSFER OF DIGITAL TOKENS. BY NOT STORING THE SECOND PRIVATE KEY AND THE SECOND PUBLIC KEY IN KEY DATA STORE 450, COMPROMISING SYSTEM 400 MAY STILL NOT ALLOW MALICIOUS USERS TO TAKE ACTION WITH RESPECT TO DIGITAL TOKENS OWNED BY THE OWNER OF SYSTEM 400, AS THESE MALICIOUS USERS MAY STILL NOT HAVE ACCESS TO THE KEYS NEEDED TO DECRYPT THE ADDRESS AT WHICH THE UNDERLYING ASSETS ASSOCIATED WITH THE DIGITAL TOKENS ARE LOCATED.

EXAMPLE CLAUSES

[0069] IMPLEMENTATION EXAMPLES ARE DESCRIBED IN THE FOLLOWING NUMBERED CLAUSES:

[0070] CLAUSE 1: A METHOD, COMPRISING: RECEIVING A REQUEST TO CREATE A DIGITAL TOKEN CORRESPONDING TO AN ASSET; RECEIVING A FIRST PRIVATE KEY ASSOCIATED WITH A WALLET IN WHICH THE DIGITAL TOKEN IS TO BE STORED; RECEIVING, FROM A PHYSICAL DEVICE ASSOCIATED WITH AN OWNER OF THE ASSET, A SECOND PRIVATE KEY; ENCRYPTING AN ADDRESS OF THE ASSET WITH A PUBLIC KEY ASSOCIATED WITH THE SECOND PRIVATE KEY; ENCRYPTING METADATA ASSOCIATED WITH THE DIGITAL TOKEN WITH A PUBLIC KEY ASSOCIATED WITH THE FIRST PRIVATE KEY; AND MINTING, ON A BLOCKCHAIN, THE DIGITAL TOKEN BASED ON THE ENCRYPTED ADDRESS OF THE ASSET AND THE ENCRYPTED METADATA.

[0071] CLAUSE 2: THE METHOD OF CLAUSE 1, WHEREIN RECEIVING THE SECOND PRIVATE KEY COMPRISES READING AN IDENTIFIER OF THE PHYSICAL DEVICE VIA A NEAR FIELD COMMUNICATION (NFC) DATA CONNECTION.

[0072] CLAUSE 3: THE METHOD OF CLAUSE 2, WHEREIN THE IDENTIFIER OF THE PHYSICAL DEVICE COMPRISES AN IDENTIFIER OF AN NFC CHIP ON THE PHYSICAL DEVICE.

[0073] CLAUSE 4: THE METHOD OF ANY ONE OF CLAUSES 1 THROUGH 3, WHEREIN RECEIVING THE SECOND PRIVATE KEY COMPRISES RECEIVING ENTRY OF AN IDENTIFIER ASSOCIATED WITH THE PHYSICAL DEVICE.

[0074] CLAUSE 5: THE METHOD OF CLAUSE 4, WHEREIN THE IDENTIFIER COMPRISES A SERIAL NUMBER ASSOCIATED OF THE PHYSICAL DEVICE ASSOCIATED WITH THE OWNER OF THE ASSET.

[0075] CLAUSE 6: THE METHOD OF ANY ONE OF CLAUSES 4 OR 5, WHEREIN THE IDENTIFIER COMPRISES AN IDENTIFIER OF A SUBSCRIBER IDENTIFICATION MODULE (SIM).

[0076] CLAUSE 7: THE METHOD OF ANY ONE OF CLAUSES 4 THROUGH 6, WHEREIN THE IDENTIFIER COMPRISES AN INTERNATIONAL MOBILE EQUIPMENT IDENTITY (IMEI) ASSOCIATED WITH THE PHYSICAL DEVICE.

[0077] CLAUSE 8: THE METHOD OF ANY ONE OF CLAUSES 4 THROUGH 7, WHEREIN THE IDENTIFIER COMPRISES AN IDENTIFIER OF A RADIO FREQUENCY IDENTIFIER (RFID) MODULE OF THE PHYSICAL DEVICE.

[0078] CLAUSE 9: THE METHOD OF ANY ONE OF CLAUSES 1 THROUGH 8, WHEREIN THE METADATA ASSOCIATED WITH THE DIGITAL TOKEN COMPRISES A UNIFORM RESOURCE INDICATOR (URI) IDENTIFYING A LOCATION AT WHICH THE ASSET IS STORED.

[0079] CLAUSE 10: THE METHOD OF ANY ONE OF CLAUSES 1 THROUGH 9, WHEREIN THE METADATA ASSOCIATED WITH THE DIGITAL TOKEN COMPRISES PRIVATE DATA USED TO GENERATE PUBLIC DATA STORED IN THE ASSET.

[0080] CLAUSE 11: THE METHOD OF ANY ONE OF CLAUSES 1 THROUGH 10, FURTHER COMPRISING: RECEIVING A REQUEST TO VIEW THE ASSET; RECEIVING THE SECOND PRIVATE KEY; RETRIEVING THE DIGITAL TOKEN; DECRYPTING THE ENCRYPTED ADDRESS OF THE ASSET FROM THE DIGITAL TOKEN USING THE SECOND PRIVATE KEY; AND RETURNING THE DECRYPTED ADDRESS OF THE ASSET AND THE ENCRYPTED METADATA IN THE DIGITAL TOKEN AS A SET OF PUBLIC KEY HASHES DECRYPTABLE USING THE FIRST PRIVATE KEY.

[0081] CLAUSE 12: THE METHOD OF CLAUSE 11, WHEREIN RECEIVING THE SECOND PRIVATE KEY COMPRISES READING AN IDENTIFIER OF THE PHYSICAL DEVICE VIA A NEAR FIELD COMMUNICATION (NFC) DATA CONNECTION.

[0082] CLAUSE 13: THE METHOD OF ANY ONE OF CLAUSES 1 THROUGH 12, FURTHER COMPRISING: RECEIVING A REQUEST TO TRANSFER THE DIGITAL TOKEN FROM THE WALLET TO A SECOND WALLET; REQUESTING A PUBLIC KEY ASSOCIATED WITH THE SECOND WALLET AND A PUBLIC KEY OF A SECOND PHYSICAL DEVICE TO BE ASSOCIATED WITH THE DIGITAL TOKEN; AND BASED ON THE FIRST PRIVATE KEY, THE SECOND PRIVATE KEY, THE PUBLIC KEY ASSOCIATED WITH THE SECOND WALLET, AND THE PUBLIC KEY OF THE SECOND PHYSICAL DEVICE, TRANSFERRING OWNERSHIP OF THE DIGITAL TOKEN TO A USER ASSOCIATED WITH THE SECOND WALLET.

[0083] CLAUSE 14: THE METHOD OF ANY ONE OF CLAUSES 1 THROUGH 13, WHEREIN THE DIGITAL TOKEN COMPRISES A NON-FUNGIBLE TOKEN (NFT) HAVING OWNERSHIP RECORDS MAINTAINED ON A BLOCKCHAIN.

[0084] CLAUSE 15: THE METHOD OF ANY ONE OF CLAUSES 1 THROUGH 14, FURTHER COMPRISING COMMITTING THE DIGITAL TOKEN TO THE WALLET.

[0085] CLAUSE 16: A SYSTEM, COMPRISING: A MEMORY HAVING EXECUTABLE INSTRUCTIONS STORED THEREON; AND A PROCESSOR CONFIGURED TO EXECUTE THE EXECUTABLE INSTRUCTIONS IN ORDER TO PERFORM THE OPERATIONS OF ANY ONE OF CLAUSES 1 THROUGH 15.

[0086] CLAUSE 17: A SYSTEM, COMPRISING: MEANS FOR PERFORMING THE OPERATIONS OF ANY ONE OF CLAUSES 1 THROUGH 15.

[0087] CLAUSE 18: A NON-TRANSITORY COMPUTER READABLE MEDIUM HAVING INSTRUCTIONS STORED THEREON WHICH, WHEN EXECUTED BY A PROCESSOR, CAUSES THE PROCESSOR TO PERFORM THE OPERATIONS OF ANY ONE OF CLAUSES 1 THROUGH 15.

ADDITIONAL CONSIDERATIONS

[0088] THE PRECEDING DESCRIPTION IS PROVIDED TO ENABLE ANY PERSON SKILLED IN THE ART TO PRACTICE THE VARIOUS EMBODIMENTS DESCRIBED HEREIN. VARIOUS MODIFICATIONS TO THESE EMBODIMENTS WILL BE READILY APPARENT TO THOSE SKILLED IN THE ART, AND THE GENERIC PRINCIPLES DEFINED HEREIN MAY BE APPLIED TO OTHER EMBODIMENTS. FOR EXAMPLE, CHANGES MAY BE MADE IN THE FUNCTION AND ARRANGEMENT OF ELEMENTS DISCUSSED WITHOUT DEPARTING FROM THE SCOPE OF THE DISCLOSURE. VARIOUS EXAMPLES MAY OMIT, SUBSTITUTE, OR ADD VARIOUS PROCEDURES OR COMPONENTS AS APPROPRIATE. ALSO, FEATURES DESCRIBED WITH RESPECT TO SOME EXAMPLES MAY BE COMBINED IN SOME OTHER EXAMPLES. FOR EXAMPLE, AN APPARATUS MAY BE IMPLEMENTED OR A METHOD MAY BE PRACTICED USING ANY NUMBER OF THE ASPECTS SET FORTH HEREIN. IN ADDITION, THE SCOPE OF THE DISCLOSURE IS INTENDED TO COVER SUCH AN APPARATUS OR METHOD THAT IS PRACTICED USING OTHER STRUCTURE, FUNCTIONALITY, OR STRUCTURE AND FUNCTIONALITY IN ADDITION TO, OR OTHER THAN, THE VARIOUS ASPECTS OF THE DISCLOSURE SET FORTH HEREIN. IT SHOULD BE UNDERSTOOD THAT ANY ASPECT OF THE DISCLOSURE DISCLOSED HEREIN MAY BE EMBODIED BY ONE OR MORE ELEMENTS OF A CLAIM.

[0089] AS USED HEREIN, A PHRASE REFERRING TO “AT LEAST ONE OF” A LIST OF ITEMS REFERS TO ANY COMBINATION OF THOSE ITEMS, INCLUDING SINGLE MEMBERS. AS AN EXAMPLE, “AT LEAST ONE OF: A, B, OR C” IS INTENDED TO COVER A, B, C, A-B, A-C, B-C, AND A-B-C, AS WELL AS ANY COMBINATION WITH MULTIPLES OF THE SAME ELEMENT (E.G., A-A, A-A-A, A-A-B, A-A-C, A-B-B, A-C-C, B-B, B-B-B, B-B-C, C-C, AND C-C OR ANY OTHER ORDERING OF A, B, AND C).

[0090] AS USED HEREIN, THE TERM “DETERMINING” ENCOMPASSES A WIDE VARIETY OF ACTIONS. FOR EXAMPLE, “DETERMINING” MAY INCLUDE CALCULATING, COMPUTING, PROCESSING, DERIVING, INVESTIGATING, LOOKING UP (E.G., LOOKING UP IN A TABLE, A DATABASE OR ANOTHER DATA STRUCTURE), ASCERTAINING AND THE LIKE. ALSO, “DETERMINING” MAY INCLUDE RECEIVING (E.G., RECEIVING INFORMATION), ACCESSING (E.G., ACCESSING DATA IN A MEMORY) AND THE LIKE. ALSO, “DETERMINING” MAY INCLUDE RESOLVING, SELECTING, CHOOSING, ESTABLISHING AND THE LIKE.

[0091] THE METHODS DISCLOSED HEREIN COMPRISE ONE OR MORE STEPS OR ACTIONS FOR ACHIEVING THE METHODS. THE METHOD STEPS AND/OR ACTIONS MAY BE INTERCHANGED WITH ONE ANOTHER WITHOUT DEPARTING FROM THE SCOPE OF THE CLAIMS. IN OTHER WORDS, UNLESS A SPECIFIC ORDER OF STEPS OR ACTIONS IS SPECIFIED, THE ORDER AND/OR USE

OF SPECIFIC STEPS AND/OR ACTIONS MAY BE MODIFIED WITHOUT DEPARTING FROM THE SCOPE OF THE CLAIMS. FURTHER, THE VARIOUS OPERATIONS OF METHODS DESCRIBED ABOVE MAY BE PERFORMED BY ANY SUITABLE MEANS CAPABLE OF PERFORMING THE CORRESPONDING FUNCTIONS. THE MEANS MAY INCLUDE VARIOUS HARDWARE AND/OR SOFTWARE COMPONENT(S) AND/OR MODULE(S), INCLUDING, BUT NOT LIMITED TO A CIRCUIT, AN APPLICATION SPECIFIC INTEGRATED CIRCUIT (ASIC), OR PROCESSOR. GENERALLY, WHERE THERE ARE OPERATIONS ILLUSTRATED IN FIGURES, THOSE OPERATIONS MAY HAVE CORRESPONDING COUNTERPART MEANS-PLUS-FUNCTION COMPONENTS WITH SIMILAR NUMBERING.

[0092] THE VARIOUS ILLUSTRATIVE LOGICAL BLOCKS, MODULES AND CIRCUITS DESCRIBED IN CONNECTION WITH THE PRESENT DISCLOSURE MAY BE IMPLEMENTED OR PERFORMED WITH A GENERAL PURPOSE PROCESSOR, A DIGITAL SIGNAL PROCESSOR (DSP), AN APPLICATION SPECIFIC INTEGRATED CIRCUIT (ASIC), A FIELD PROGRAMMABLE GATE ARRAY (FPGA) OR OTHER PROGRAMMABLE LOGIC DEVICE (PLD), DISCRETE GATE OR TRANSISTOR LOGIC, DISCRETE HARDWARE COMPONENTS, OR ANY COMBINATION THEREOF DESIGNED TO PERFORM THE FUNCTIONS DESCRIBED HEREIN. A GENERAL-PURPOSE PROCESSOR MAY BE A MICROPROCESSOR, BUT IN THE ALTERNATIVE, THE PROCESSOR MAY BE ANY COMMERCIALY AVAILABLE PROCESSOR, CONTROLLER, MICROCONTROLLER, OR STATE MACHINE. A PROCESSOR MAY ALSO BE IMPLEMENTED AS A COMBINATION OF COMPUTING DEVICES, E.G., A COMBINATION OF A DSP AND A MICROPROCESSOR, A PLURALITY OF MICROPROCESSORS, ONE OR MORE MICROPROCESSORS IN CONJUNCTION WITH A DSP CORE, OR ANY OTHER SUCH CONFIGURATION.

[0093] A PROCESSING SYSTEM MAY BE IMPLEMENTED WITH A BUS ARCHITECTURE. THE BUS MAY INCLUDE ANY NUMBER OF INTERCONNECTING BUSES AND BRIDGES DEPENDING ON THE SPECIFIC APPLICATION OF THE PROCESSING SYSTEM AND THE OVERALL DESIGN CONSTRAINTS. THE BUS MAY LINK TOGETHER VARIOUS CIRCUITS INCLUDING A PROCESSOR, MACHINE-READABLE MEDIA, AND INPUT/OUTPUT DEVICES, AMONG OTHERS. A USER INTERFACE (E.G., KEYPAD, DISPLAY, MOUSE, JOYSTICK, ETC.) MAY ALSO BE CONNECTED TO THE BUS. THE BUS MAY ALSO LINK VARIOUS OTHER CIRCUITS SUCH AS TIMING SOURCES, PERIPHERALS, VOLTAGE REGULATORS, POWER MANAGEMENT CIRCUITS, AND THE LIKE, WHICH ARE WELL KNOWN IN THE ART, AND THEREFORE, WILL NOT BE DESCRIBED ANY FURTHER. THE PROCESSOR MAY BE IMPLEMENTED WITH ONE OR MORE GENERAL-PURPOSE AND/OR SPECIAL-PURPOSE PROCESSORS. EXAMPLES INCLUDE MICROPROCESSORS, MICROCONTROLLERS, DSP PROCESSORS, AND OTHER CIRCUITRY THAT CAN EXECUTE SOFTWARE. THOSE SKILLED IN THE ART WILL RECOGNIZE HOW BEST TO IMPLEMENT THE DESCRIBED FUNCTIONALITY FOR THE PROCESSING SYSTEM DEPENDING ON THE PARTICULAR APPLICATION AND THE OVERALL DESIGN CONSTRAINTS IMPOSED ON THE OVERALL SYSTEM.

[0094] IF IMPLEMENTED IN SOFTWARE, THE FUNCTIONS MAY BE STORED OR TRANSMITTED OVER AS ONE OR MORE INSTRUCTIONS OR CODE ON A COMPUTER-READABLE MEDIUM. SOFTWARE SHALL BE CONSTRUED BROADLY TO MEAN INSTRUCTIONS, DATA, OR ANY COMBINATION THEREOF, WHETHER REFERRED TO AS SOFTWARE, FIRMWARE, MIDDLEWARE, MICROCODE, HARDWARE DESCRIPTION LANGUAGE, OR OTHERWISE. COMPUTER-READABLE MEDIA INCLUDE BOTH COMPUTER STORAGE MEDIA AND COMMUNICATION MEDIA, SUCH AS ANY MEDIUM THAT FACILITATES TRANSFER OF A COMPUTER PROGRAM FROM ONE PLACE TO ANOTHER. THE PROCESSOR MAY BE RESPONSIBLE FOR MANAGING THE BUS AND GENERAL PROCESSING,

INCLUDING THE EXECUTION OF SOFTWARE MODULES STORED ON THE COMPUTER-READABLE STORAGE MEDIA. A COMPUTER-READABLE STORAGE MEDIUM MAY BE COUPLED TO A PROCESSOR SUCH THAT THE PROCESSOR CAN READ INFORMATION FROM, AND WRITE INFORMATION TO, THE STORAGE MEDIUM. IN THE ALTERNATIVE, THE STORAGE MEDIUM MAY BE INTEGRAL TO THE PROCESSOR. BY WAY OF EXAMPLE, THE COMPUTER-READABLE MEDIA MAY INCLUDE A TRANSMISSION LINE, A CARRIER WAVE MODULATED BY DATA, AND/OR A COMPUTER READABLE STORAGE MEDIUM WITH INSTRUCTIONS STORED THEREON SEPARATE FROM THE WIRELESS NODE, ALL OF WHICH MAY BE ACCESSED BY THE PROCESSOR THROUGH THE BUS INTERFACE. ALTERNATIVELY, OR IN ADDITION, THE COMPUTER-READABLE MEDIA, OR ANY PORTION THEREOF, MAY BE INTEGRATED INTO THE PROCESSOR, SUCH AS THE CASE MAY BE WITH CACHE AND/OR GENERAL REGISTER FILES. EXAMPLES OF MACHINE-READABLE STORAGE MEDIA MAY INCLUDE, BY WAY OF EXAMPLE, RAM (RANDOM ACCESS MEMORY), FLASH MEMORY, ROM (READ ONLY MEMORY), PROM (PROGRAMMABLE READ-ONLY MEMORY), EPROM (ERASABLE PROGRAMMABLE READ-ONLY MEMORY), EEPROM (ELECTRICALLY ERASABLE PROGRAMMABLE READ-ONLY MEMORY), REGISTERS, MAGNETIC DISKS, OPTICAL DISKS, HARD DRIVES, OR ANY OTHER SUITABLE STORAGE MEDIUM, OR ANY COMBINATION THEREOF. THE MACHINE-READABLE MEDIA MAY BE EMBODIED IN A COMPUTER-PROGRAM PRODUCT.

[0095] A SOFTWARE MODULE MAY COMPRISE A SINGLE INSTRUCTION, OR MANY INSTRUCTIONS, AND MAY BE DISTRIBUTED OVER SEVERAL DIFFERENT CODE SEGMENTS, AMONG DIFFERENT PROGRAMS, AND ACROSS MULTIPLE STORAGE MEDIA. THE COMPUTER-READABLE MEDIA MAY COMPRISE A NUMBER OF SOFTWARE MODULES. THE SOFTWARE MODULES INCLUDE INSTRUCTIONS THAT, WHEN EXECUTED BY AN APPARATUS SUCH AS A PROCESSOR, CAUSE THE PROCESSING SYSTEM TO PERFORM VARIOUS FUNCTIONS. THE SOFTWARE MODULES MAY INCLUDE A TRANSMISSION MODULE AND A RECEIVING MODULE. EACH SOFTWARE MODULE MAY RESIDE IN A SINGLE STORAGE DEVICE OR BE DISTRIBUTED ACROSS MULTIPLE STORAGE DEVICES. BY WAY OF EXAMPLE, A SOFTWARE MODULE MAY BE LOADED INTO RAM FROM A HARD DRIVE WHEN A TRIGGERING EVENT OCCURS. DURING EXECUTION OF THE SOFTWARE MODULE, THE PROCESSOR MAY LOAD SOME OF THE INSTRUCTIONS INTO CACHE TO INCREASE ACCESS SPEED. ONE OR MORE CACHE LINES MAY THEN BE LOADED INTO A GENERAL REGISTER FILE FOR EXECUTION BY THE PROCESSOR. WHEN REFERRING TO THE FUNCTIONALITY OF A SOFTWARE MODULE, IT WILL BE UNDERSTOOD THAT SUCH FUNCTIONALITY IS IMPLEMENTED BY THE PROCESSOR WHEN EXECUTING INSTRUCTIONS FROM THAT SOFTWARE MODULE.

[0096] THE FOLLOWING CLAIMS ARE NOT INTENDED TO BE LIMITED TO THE EMBODIMENTS SHOWN HEREIN, BUT ARE TO BE ACCORDED THE FULL SCOPE CONSISTENT WITH THE LANGUAGE OF THE CLAIMS. WITHIN A CLAIM, REFERENCE TO AN ELEMENT IN THE SINGULAR IS NOT INTENDED TO MEAN "ONE AND ONLY ONE" UNLESS SPECIFICALLY SO STATED, BUT RATHER "ONE OR MORE." UNLESS SPECIFICALLY STATED OTHERWISE, THE TERM "SOME" REFERS TO ONE OR MORE. NO CLAIM ELEMENT IS TO BE CONSTRUED UNDER THE PROVISIONS OF 35 U.S.C. §112(F) UNLESS THE ELEMENT IS EXPRESSLY RECITED USING THE PHRASE "MEANS FOR" OR, IN THE CASE OF A METHOD CLAIM, THE ELEMENT IS RECITED USING THE PHRASE "STEP FOR." ALL STRUCTURAL AND FUNCTIONAL EQUIVALENTS TO THE ELEMENTS OF THE VARIOUS ASPECTS DESCRIBED THROUGHOUT THIS DISCLOSURE THAT ARE KNOWN OR LATER COME TO BE KNOWN TO THOSE OF ORDINARY SKILL IN THE ART ARE EXPRESSLY INCORPORATED HEREIN BY REFERENCE AND ARE INTENDED TO BE ENCOMPASSED BY THE CLAIMS. MOREOVER, NOTHING DISCLOSED HEREIN IS INTENDED TO BE

DEDICATED TO THE PUBLIC REGARDLESS OF WHETHER SUCH DISCLOSURE IS EXPLICITLY
RECITED IN THE CLAIMS.

WHAT IS CLAIMED IS:

1. A METHOD, COMPRISING:

- RECEIVING A REQUEST TO CREATE A DIGITAL TOKEN CORRESPONDING TO AN ASSET;
 - RECEIVING A FIRST PRIVATE KEY ASSOCIATED WITH A WALLET IN WHICH THE DIGITAL TOKEN IS TO BE STORED;
 - RECEIVING, FROM A PHYSICAL DEVICE ASSOCIATED WITH AN OWNER OF THE ASSET, A SECOND PRIVATE KEY;
 - ENCRYPTING AN ADDRESS OF THE ASSET WITH A PUBLIC KEY ASSOCIATED WITH THE SECOND PRIVATE KEY;
 - ENCRYPTING METADATA ASSOCIATED WITH THE DIGITAL TOKEN WITH A PUBLIC KEY ASSOCIATED WITH THE FIRST PRIVATE KEY; AND MINTING, ON A BLOCKCHAIN, THE DIGITAL TOKEN BASED ON THE ENCRYPTED ADDRESS OF THE ASSET AND THE ENCRYPTED METADATA.

2. THE METHOD OF CLAIM 1, WHEREIN RECEIVING THE SECOND PRIVATE KEY COMPRISES READING AN IDENTIFIER OF THE PHYSICAL DEVICE VIA A NEAR FIELD COMMUNICATION (NFC) DATA CONNECTION.

3. THE METHOD OF CLAIM 2, WHEREIN THE IDENTIFIER OF THE PHYSICAL DEVICE COMPRISES AN IDENTIFIER OF AN NFC CHIP ON THE PHYSICAL DEVICE.

4. THE METHOD OF CLAIM 1, WHEREIN RECEIVING THE SECOND PRIVATE KEY COMPRISES RECEIVING ENTRY OF AN IDENTIFIER ASSOCIATED WITH THE PHYSICAL DEVICE.

5. THE METHOD OF CLAIM 4, WHEREIN THE IDENTIFIER COMPRISES A SERIAL NUMBER ASSOCIATED OF THE PHYSICAL DEVICE ASSOCIATED WITH THE OWNER OF THE ASSET.

6. THE METHOD OF CLAIM 4, WHEREIN THE IDENTIFIER COMPRISES AN IDENTIFIER OF A SUBSCRIBER IDENTIFICATION MODULE (SIM).

7. THE METHOD OF CLAIM 4, WHEREIN THE IDENTIFIER COMPRISES AN INTERNATIONAL MOBILE EQUIPMENT IDENTITY (IMEI) ASSOCIATED WITH THE PHYSICAL DEVICE.

8. THE METHOD OF CLAIM 4, WHEREIN THE IDENTIFIER COMPRISES AN IDENTIFIER OF A RADIO FREQUENCY IDENTIFIER (RFID) MODULE OF THE PHYSICAL DEVICE.

9. THE METHOD OF CLAIM 1, WHEREIN THE METADATA ASSOCIATED WITH THE DIGITAL TOKEN COMPRISES A UNIFORM RESOURCE INDICATOR (URI) IDENTIFYING A LOCATION AT WHICH THE ASSET IS STORED.

10. THE METHOD OF CLAIM 1, WHEREIN THE METADATA ASSOCIATED WITH THE DIGITAL TOKEN COMPRISES PRIVATE DATA USED TO GENERATE PUBLIC DATA STORED IN THE ASSET.

11. THE METHOD OF CLAIM 1, FURTHER COMPRISING:

- RECEIVING A REQUEST TO VIEW THE ASSET; RECEIVING THE SECOND PRIVATE KEY; RETRIEVING THE DIGITAL TOKEN;

- DECRYPTING THE ENCRYPTED ADDRESS OF THE ASSET FROM THE DIGITAL TOKEN USING THE SECOND PRIVATE KEY; AND
- RETURNING THE DECRYPTED ADDRESS OF THE ASSET AND THE ENCRYPTED METADATA IN THE DIGITAL TOKEN AS A SET OF PUBLIC KEY HASHES DECRYPTABLE USING THE FIRST PRIVATE KEY.

12. THE METHOD OF CLAIM 11, WHEREIN RECEIVING THE SECOND PRIVATE KEY COMPRISES READING AN IDENTIFIER OF THE PHYSICAL DEVICE VIA A NEAR FIELD COMMUNICATION (NFC) DATA CONNECTION.

13. THE METHOD OF CLAIM 1, FURTHER COMPRISING:

- RECEIVING A REQUEST TO TRANSFER THE DIGITAL TOKEN FROM THE WALLET TO A SECOND WALLET;
- REQUESTING A PUBLIC KEY ASSOCIATED WITH THE SECOND WALLET AND A PUBLIC KEY OF A SECOND PHYSICAL DEVICE TO BE ASSOCIATED WITH THE DIGITAL TOKEN; AND
- BASED ON THE FIRST PRIVATE KEY, THE SECOND PRIVATE KEY, THE PUBLIC KEY ASSOCIATED WITH THE SECOND WALLET, AND THE PUBLIC KEY OF THE SECOND PHYSICAL DEVICE, TRANSFERRING OWNERSHIP OF THE DIGITAL TOKEN TO A USER ASSOCIATED WITH THE SECOND WALLET.

14. THE METHOD OF CLAIM 1, WHEREIN THE DIGITAL TOKEN COMPRISES A NON-FUNGIBLE TOKEN (NFT) HAVING OWNERSHIP RECORDS MAINTAINED ON A BLOCKCHAIN.

15. THE METHOD OF CLAIM 1, FURTHER COMPRISING COMMITTING THE DIGITAL TOKEN TO THE WALLET.

16. A SYSTEM, COMPRISING:

- A MEMORY HAVING EXECUTABLE INSTRUCTIONS STORED THEREON; AND
 - A PROCESSOR CONFIGURED TO EXECUTE THE EXECUTABLE INSTRUCTIONS IN ORDER TO PERFORM THE OPERATIONS OF ANY ONE OF CLAIMS 1 THROUGH 15.

17. A SYSTEM, COMPRISING:

- MEANS FOR PERFORMING THE OPERATIONS OF ANY ONE OF CLAIMS 1 THROUGH 15.

18. A NON-TRANSITORY COMPUTER READABLE MEDIUM HAVING INSTRUCTIONS STORED THEREON WHICH, WHEN EXECUTED BY A PROCESSOR, CAUSES THE PROCESSOR TO PERFORM THE OPERATIONS OF ANY ONE OF CLAIMS 1 THROUGH 15.

ABSTRACT

CERTAIN ASPECTS OF THE PRESENT DISCLOSURE PROVIDE TECHNIQUES FOR GENERATING DIGITAL TOKENS ASSOCIATED WITH AN ASSET ON A BLOCKCHAIN. AN EXAMPLE METHOD GENERALLY INCLUDES RECEIVING A REQUEST TO CREATE A DIGITAL TOKEN CORRESPONDING TO AN ASSET. A FIRST PRIVATE KEY IS RECEIVED. THIS FIRST PRIVATE KEY MAY BE ASSOCIATED WITH A WALLET IN WHICH THE DIGITAL TOKEN IS TO BE STORED. A SECOND PRIVATE KEY IS RECEIVED FROM A PHYSICAL DEVICE ASSOCIATED WITH AN OWNER OF THE ASSET. AN ADDRESS OF THE ASSET IS ENCRYPTED WITH A PUBLIC KEY ASSOCIATED WITH THE SECOND PRIVATE KEY. METADATA ASSOCIATED WITH THE DIGITAL TOKEN IS ENCRYPTED

WITH A PUBLIC KEY ASSOCIATED WITH THE FIRST PRIVATE KEY. THE DIGITAL TOKEN IS MINTED ON A BLOCKCHAIN BASED ON THE ENCRYPTED ADDRESS OF THE ASSET AND THE ENCRYPTED METADATA.

3.4 PHYSICAL NFT ESCROW

IN RESEARCH & DEVELOPMENT PHASES

THE ESCROW PROCESS FOR PHYSICAL OBJECTS, VIA SMART CONTRACTS, IS AN ADDED BLOCKCHAIN TECHNOLOGY WHICH IS UNIQUE TO **LITH TOKEN**.

3.5 ROYALTIES

IN RESEARCH & DEVELOPMENT PHASES

SPLIT ROYALTIES AND STACKED ROYALTIES FOR NFT'S, VIA SMART CONTRACTS, IS AN ADDED BLOCKCHAIN TECHNOLOGY WHICH IS UNIQUE TO **LITH TOKEN**.

TOKENOMICS

4.1 ETHEREUM

LITH TOKEN IS CURRENTLY AN ERC-20 TOKEN (**LITH**) THAT WILL BE UPGRADED TO A NEW ERC-20 CONTRACT (**LITx**) WHICH WILL INCLUDE INTEGRATION WITH AN ERC-1155 TOKEN (**LITHplus**) ON THE ETHEREUM BLOCKCHAIN. ETHEREUM IS ONE OF OUR GREATEST ALLIES IN INNOVATIVE TECHNOLOGY DURING A TIME WHERE CRYPTOCURRENCY HAS TAKEN SOLID ROOTS AS AN ALL-IN-ONE, INNOVATIVE WAY TO HANDLE FINANCE AND SUPPLY CHAIN LOGISTICS. FROM LAUNCH TO PRESENT, ETHEREUM HAS BEEN THE LITERAL BACKBONE OF **LITH TOKEN**'S INNOVATIVE TECHNOLOGICAL VENTURES AND WE ARE PROUD TO STAND BY THEM AS AN INNOVATIVE USER OF IT'S TECHNOLOGIES.

ON THE ETHEREUM NETWORK, THERE IS A CONCEPT OF A GREEN PERIOD OR "GREENING PERIOD". DURING THIS PERIOD, TOKENS GO FROM AN ERC-20 TOKEN CONTRACT TO A NEW GREEN TOKEN CONTRACT, NATURALLY. THE BLOCKCHAIN CONSENSUS MECHANISM ON THE ETHEREUM NETWORKS WILL SOON BE CHANGING FROM A PROOF OF WORK PROTOCOL TO A PROOF OF STAKE PROTOCOL TO PERPETUATE THE TRANSITION.

ETHEREUM BLOCKCHAIN ITSELF WILL ALSO IMPLEMENT A GREENING PERIOD FOR ETHEREUM 2.0 IN WHICH MANY CONTRACTS WILL BE GREENED AND WILL BECOME GREEN CONTRACTS ON THE NEW PROTOCOL. ETH 2.0 TOKENS ARE GREEN BY DEFAULT, SO THEY DO NOT REQUIRE A GREENING PERIOD TO MOVE FROM AN ERC-20 CONTRACT TO THE GREEN CONTRACT.

[CLICK HERE](#) TO READ ABOUT THE ETHEREUM WHITEPAPER IN ORDER TO UNDERSTAND THE PROTOCOL THE ERC-20 TOKEN STANDARD IS BUILT ON.

4.2 TOKENOMICS

\$LITH IS A CRYPTOCURRENCY WITH 10 BILLION TOKENS EXECUTED, LAUNCHED ON MAY 31, 2021 AT A PRICE OF \$0.00000243 USD. AN EVENTUAL MIGRATION TO \$LITx WILL HAVE A PERMANENT SUPPLY OF ~5.4 BILLION TOKENS.

REDISTRIBUTION

FOR A LIMITED TIME, EACH TRANSACTION HAS AN ASSOCIATED 5% TRANSACTION FEE. 40% OF THESE FEES ARE BURNED WHILE THE OTHER 60% REDISTRIBUTES INTO **LITH**'S LIQUIDITY POOL WHERE IT'S IMMEDIATELY REDISTRIBUTED TO ALL HOLDERS PROPORTIONALLY BASED ON THEIR HOLDINGS. WHEN **\$LITH** WAS FIRST LAUNCHED, ONLY FIVE AND A HALF BILLION TOKENS WERE PUT INTO CIRCULATION WITH A STARTING LIQUIDITY POOL OF 10 ETH.

AS THIS IS ONLY A METHOD TO REWARD EARLY ADOPTERS, THIS PORTION OF THE ERC-20 SMART CONTRACT WILL END UPON MIGRATION TO **LITx**.

4.3 LITH TOKEN ECOSYSTEM

LITH TOKEN IS CURRENTLY USING THE ERC-20 PROTOCOL (LITH) AS A BASIC EARLY ADOPTION VEHICLE IN ORDER TO CREATE DEMAND FOR THE LITH ECOSYSTEM AND WILL SOON BE MIGRATED TO THE NEW ERC-20 CONTRACT (LITx) & ERC-1155 (LITHplus), WHICH IS AN UPGRADED SET OF CONTRACTS THAT HAVE A FASTER TRANSACTION TIME AND CAN STORE MORE INFORMATION IN ITS BLOCKS. THE PRODUCTION PROCESS OF LITH TOKEN IS OPEN TO THE PUBLIC ON THE BLOCKCHAIN IN ORDER TO TRACK WHERE THEY COME FROM. ALL TOKENS STAY PROTECTED WITH TRUSTED THIRD-PARTY WALLETS AND EXCHANGES WHILE REMAINING EASILY TRADABLE IF NEEDED.

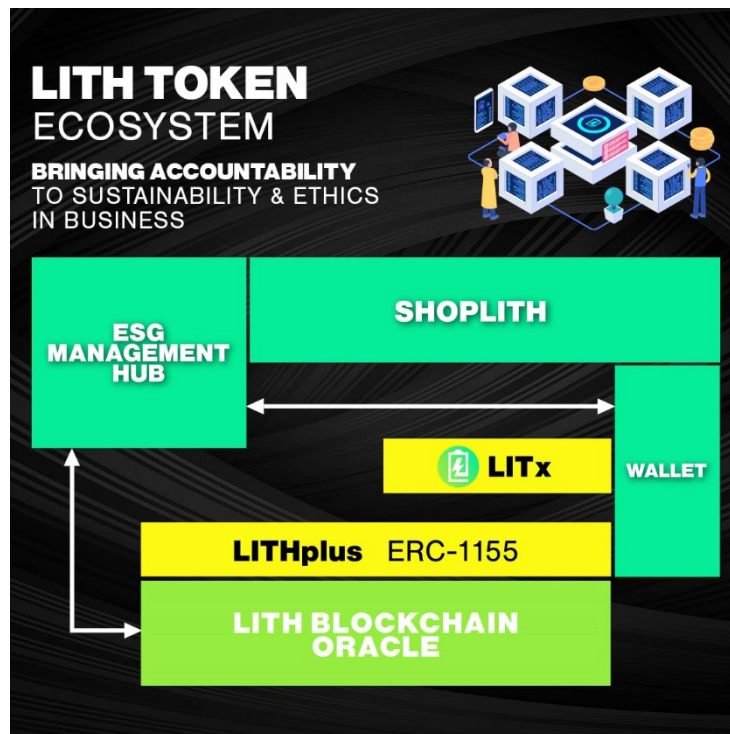

4.4 ERC-1155

THE ERC-1155 TOKEN IS QUICKLY BECOMING THE NEW STANDARD FOR TOKENS LOOKING TO UTILIZE NFTS IN COMBINATION WITH FUNGIBLE TOKENS. UNLIKE OTHER PROTOCOLS, ERC-1155 ISN'T RESTRICTED BY SCALABILITY OR HIGH TRANSACTION FEES, ALLOWING FOR A GREATER NUMBER OF DIRECT BLOCKCHAIN APPLICATIONS. ERC-1155 TOKENS ARE IMPLEMENTED ON THE ETHEREUM NETWORK RATHER THAN ON A STAND-ALONE CHAIN, MAKING THEM EASIER AND CHEAPER FOR DEVELOPERS TO WORK WITH. THESE FEATURES NOT ONLY MAKE THE ERC-1155 PROTOCOL FASTER, BUT ALSO LOWER COSTS THROUGH INCREASED EFFICIENCY AND REDUCED POWER CONSUMPTION FROM MINING AND EQUIPMENT, DUE TO THE FUTURE LACK OF NEED FOR PROOF OF WORK CONSENSUS MECHANISMS.

4.5 UNISWAP

WHILE ERC-1155 TOKENS ARE NOT WIDELY ACCEPTED ON EVERY EXCHANGE, WE ARE ABLE TO USE THE ERC-20 TOKENS TO EXCHANGE FOR THE ERC-1155 TOKENS FOR USE ON THE **LITH BLOCKCHAIN HUB** TO STORE DATA. UNTIL THE ERC-1155 HAS A COMMON PUBLIC FACING SOLUTION FOR EXCHANGE, THE [UNISWAP V2 PROTOCOL](#) IS AVAILABLE FOR USE TO CREATE ERC-20 TOKEN LIQUIDITY ON THE ETHEREUM BLOCKCHAIN. CROSS ASSET SWAPPING IS ALSO ABLE TO BE UTILIZED AND WILL BE USED IN COMBINATION WITH A LAYER 2 SOLUTION TO KEEP TRANSACTIONS EFFICIENT AND EFFECTIVE. (OTHER EXCHANGES ARE PLANNED TO BE ADDED)

4.6 WHY LITH TOKEN?

LITH'S MAIN GOAL IS TO SUPPORT A MORE SUSTAINABLE FUTURE BY PROVIDING A PLATFORM FOR PRIVATE INDIVIDUALS, COMPANIES, AND INSTITUTIONAL ENTITIES WITH A SHARED OBJECTIVE: ACCELERATING THE ACCESS TO MORE SUSTAINABLE ALTERNATIVES AND TECHNOLOGIES.

THE INCREASING DEMAND OF EVS ALONG WITH THE SCARCE SUPPLY OF LITHIUM HAS STARTED A RACE FOR COMPANIES TO BECOME THE LEADING MANUFACTURER OF LITHIUM BATTERIES AS HAS BEEN SHOWCASED IN SEVERAL ARTICLES; OILPRICE: THE WORLD IS IN DESPERATE NEED OF MORE LITHIUM, SEEKING ALPHA: ALL EV ROADS LEAD TO LITHIUM MINERS AND BATTERY PRODUCERS, REUTERS: BATTERY DEFICIT RISKS UK DRIVING ELECTRIC JALOPY. CHINA IS THE CURRENTLY LEADING THE PACK BY A SIGNIFICANT MARGIN AS BENCHMARK MINERALS SHOWS: GLOBAL BATTERIES ARM RACE: 200 GIGAFATORIES; CHINA LEADS, CHINA IS BUILDING ONE GIGAFATORY A WEEK; THE USE ONE ONE EVERY FOUR MONTHS.

WHILE THIS IS GREAT NEWS FOR AN ACCELERATED ENERGY TRANSITION, THE PRICE TO PAY CANNOT BE THE DEGRADATION OF THE ENVIRONMENT DUE TO THE AGGRESSIVE LITHIUM MINING AND EXTRACTION TECHNIQUES THAT ARE CURRENTLY IN USE. **LITH'S** STRATEGIC PARTNERSHIPS AIM TO PAVE THE WAY FOR A MORE SUSTAINABLE AND ENVIRONMENTALLY FRIENDLY FUTURE BY TACKLING THE PROBLEMS THAT LIE WITH THE CURRENT MODEL OF LITHIUM EXTRACTION, BATTERY MANUFACTURING AND MASS ADOPTION OF ELECTRIC ALTERNATIVES.

LITH HAS BEEN INSPIRED TO TAKE IT A STEP FURTHER INTO THE ENTIRE ENVIRONMENTAL, SOCIAL AND GOVERNANCE LANDSCAPE. WITH ESG STANDARDS GENERALLY BEING SET BY CENTRAL GOVERNING BODIES AND INDIVIDUAL ENTITIES FOLLOWING THEIR OWN BIASES WHEN IMPLEMENTING ESG SCORING. **LITH** AND ITS PARTNERS ARE WORKING TO RESOLVE THE MANY ISSUES SURROUNDING CURRENT ESG MODELS WHILE INCENTIVIZING EVERYONE TO WORK TOGETHER TO REVOLUTIONIZE THE WAY WE APPROACH ETHICS IN BUSINESS.

4.7 LITH TOKEN CHARACTERISTICS

LITH TOKEN IS BACKED BY THE TRANSPARENT INFORMATION ON ESG COMPANIES STORED ON THE BLOCKCHAIN. THIS MEANS EACH **LITH TOKEN** REPRESENTS AN EQUAL VALUE IN RELATION TO THE DEMAND FOR THIS DATA, AND CAN BE USED AS TRADING CURRENCY FOR PRODUCTS FROM THESE COMPANIES AS WELL AS OTHER CRYPTOCURRENCIES.

LITH TOKENS ARE TRADED IN AN OPEN MARKET THAT IS FREELY ACCESSIBLE TO EVERYONE. THEY CAN BE STORED IN THE USER'S PERSONAL ACCOUNT OR ANY THIRD PARTY CRYPTOCURRENCY WALLET, SUCH AS METAMASK (AT ANYTIME). USERS RETAIN FULL OWNERSHIP OF THEIR TOKENS.

LITH TOKEN INCENTIVIZES ETHICAL BUSINESS PRACTICES BY REWARDING INTERACTIONS AND MAINTAINING ESG STANDARDS. THIS IS DONE THROUGH THE **LITH** ECOSYSTEM, WHICH ALSO HELPS TO SOLIDIFY WHAT IT MEANS WHEN COMPANIES STATE THAT THEY ARE "ESG-FRIENDLY".

IN THE DEVELOPMENT PROCESS OF **LITH TOKEN**, TOKEN HOLDERS CAN USE **LITH** TO SET THE DEMAND LEVELS FOR DECENTRALIZED ENVIRONMENTAL SOCIAL GOVERNANCE STANDARDS BY EXCHANGING ETH FOR **\$LITx**.

THE **LITH TOKEN** IS A UNIVERSAL BENCHMARK FOR GLOBAL SUSTAINABILITY. IT ENABLES COMPANIES TO TRACK THEIR PROGRESS AND TRANSPARENCY ACROSS THE WORLD, AS WELL AS CREATE SUSTAINABLE VALUE ON AN INTERNATIONAL SCALE.

THE **LITH TOKEN** ECOSYSTEM CONTINUES TO GROW THROUGH PARTNERSHIPS LIKE THOSE WITH ENSORCIA METALS. THESE NEWLY FORMED RELATIONSHIPS NOT ONLY BRING VALUE TO THE PLATFORM, BUT ALSO HELP KEEP USERS INFORMED ABOUT UPCOMING PRODUCTS FROM OUR NEWEST PARTNERS. THE CORE TEAM IS WORKING TIRELESSLY ON NURTURING THE RELATIONSHIP WITH BOTH ENSORCIA METALS AND OTHER INTERESTED PARTIES IN ORDER TO FIND A WAY FORWARD THAT SATISFIES EVERYONE INVOLVED FOR YEARS INTO THE FUTURE.

4.7.1 LITH (ERC-20) SYSTEM TECHNICAL OVERVIEW

LITH IS A MIXED-PURPOSE SYSTEM WITH THE FOLLOWING CONTRACTS:

- **LITX** - UPGRADEABLE ERC-20 TOKEN THAT MINTS ALL INITIAL SUPPLY TO THE TOKEN CONTRACT. ADDITIONAL MINTING IS ALLOWED. TAKES A 1% FEE FROM EVERY TRANSFER.

HAS A BAN SYSTEM, AND BANNED USERS CANNOT MIGRATE THEIR \$LITH TOKENS.

HAS A MIGRATION MECHANISM BETWEEN \$LITH TO \$LITX TOKEN WITH A 1:1 RATE.

WILL TRANSFER ALL REMAINING BALANCE ON THE CONTRACT TO THE ECOSYSTEM NAMED ADDRESS AFTER THE SPECIFIED TIME (60 DAYS), WHICH WILL BE SET DURING DEPLOYMENT, PASS, AND WILL NO LONGER SUPPORT MIGRATIONS.

HAS BRIDGE SUPPORT, AND IT CAN MINT AND BURN THE DESIRED AMOUNT OF TOKENS ACCORDING TO THE BRIDGE ORDER. THE TOTAL SUPPLY BETWEEN CHAINS REMAINS INTACT.

IT HAS THE FOLLOWING ATTRIBUTES:

- NAME: LITX TOKEN
 - SYMBOL: LITX
 - DECIMALS: 18
 - TOTAL SUPPLY: 5.417.770.823
- **LITH** - UPGRADEABLE ERC20 TOKEN THAT MINTS ALL INITIAL SUPPLY TO THE DEPLOYER. IT IS USED FOR SIMULATING A 1-TO-1 (EQUAL PARTS OF CIRCULATING SUPPLY) \$LITH TO \$LITX MIGRATION.

IT HAS THE FOLLOWING RATES TO DISTRIBUTE TOKENS:

- NAME: LITH TOKEN
 - SYMBOL: LITH
 - DECIMALS: 18
 - INITIAL SUPPLY: 10.000.000.000
- **MERKLEDISTRIBUTOR** - AN ABSTRACT CONTRACT FOR DISTRIBUTING TOKENS TO PREDEFINED ADDRESSES USING THE MERKLE TREE ALGORITHM.
 - **FEEDISTRIBUTOR** - UPGRADEABLE CONTRACT USED FOR DISTRIBUTING \$LITX FEES COLLECTED FROM USER TRANSFERS. IT IS PLANNED TO DISTRIBUTE THE COLLECTED FEES IN 4 SEPARATE TITLES, WHICH ARE DEVELOPER, ECOSYSTEM, MARKETING, AND REWARD.

USES MERKLEDISTRIBUTOR CONTRACT TO VERIFY WHETHER THE REWARD IS COLLECTED OR NOT. IF THE REWARD HAS NOT BEEN COLLECTED WITHIN THIRTY (30) DAYS THE UNCOLLECTED AMOUNT CARRIES OVER TO THE NEXT ROUND OF THE REWARD DISTRIBUTION.

IT USES THE FOLLOWING RATIOS FOR TOKEN DISTRIBUTION:

- ECOSYSTEM: 60%
 - MARKETING: 20%
 - DEVELOPERS: 10%
 - REWARDS: 10%
- **BANNEDUPGRADEABLE** - AN ABSTRACT CONTRACT THAT IMPLEMENTS A BAN SYSTEM. IT HAS THE PROPERTIES OF BANNING AND UNBANNING ADDRESSES.

PRIVILEGED ROLES

- THE OWNER OF THE LITX CONTRACT HAS THE FOLLOWING PRIVILEGES:
 - CAN CHANGE FEE DISTRIBUTOR CONTRACT ADDRESS.
 - CAN BAN AND UNBAN AN ADDRESS.

- THE BRIDGE PRIVILEGE CAN MINT AND BURN THE DESIRED AMOUNT OF \$LITX TO ANY ADDRESS.
- THE OWNER OF FEEDISTRIBUTOR CONTRACT HAS THE FOLLOWING PRIVILEGES:
 - CAN CHANGE THE DEVELOPER ADDRESSES.
 - CAN CHANGE MERKLE ROOT, AND IF NOT CLAIMED REWARDS ARE LEFT WITH THE PREVIOUS ROOT TO BE USED FOR NEXT MONTH'S REWARDS, USERS CANNOT CLAIM THEIR REWARDS ANYMORE.
 - CAN DISTRIBUTE COLLECTED FEES TO DEVELOPERS, ECOSYSTEM, AND MARKETING ADDRESSES WITH THE MENTIONED RATIO.

4.8 BLOCKCHAIN BRIDGES

BLOCKCHAIN BRIDGES CREATE COMMUNICATIONS BETWEEN DIFFERENT BLOCKCHAIN NETWORKS. **LITH TOKEN (\$LITx)** WILL BE BRIDGED TO A MINIMUM OF ONE OTHER BLOCKCHAIN TO ALLOW FOR USERS TO HAVE MULTIPLE ACCESS POINTS TO THE **LITH** ECOSYSTEM. **LITH** HAS AN EXISTING BRIDGE (VERSION 1.0) CREATED FOR THE BINANCE SMART CHAIN NETWORK AND WILL BE INTEGRATED IN AN UPDATED VERSION WHICH IS MORE GAS (gwei) EFFICIENT. THE UPDATED BRIDGE IS CREATED USING SIMILAR CONTRACTS WHICH COMMUNICATE WITH EACH OTHER VIA A BACKEND NODE.

4.9.0 PROXY CONTRACTS

\$LITx USES PROXY CONTRACTS AND A PROXY MANAGER IN ORDER TO MINIMIZE THE CONTRACT SIZE UTILIZED IN EACH USER TRANSACTION.

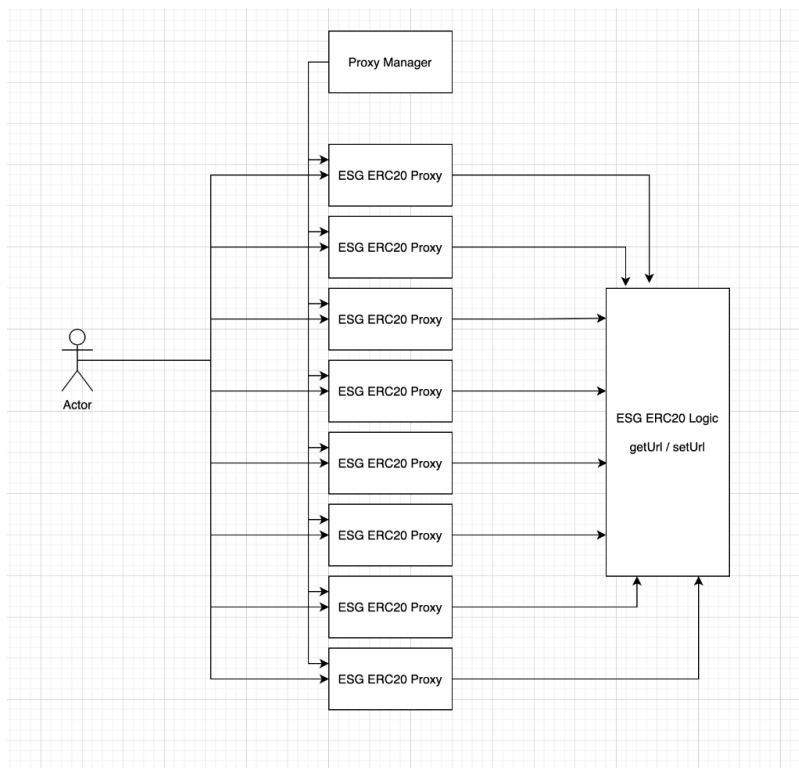

4.9.1 MARKETPLACE ECOSYSTEM

WITHIN THE ECOSYSTEM, THERE IS A 1% TAX ON EACH \$LITx TRANSACTION WHICH WILL BE REDISTRIBUTED FOR ENGAGEMENT REWARDS, ECOSYSTEM MAINTENANCE, CONTINUOUS INTEGRATION DEVELOPMENT & ONGOING MARKETING PROJECTS.

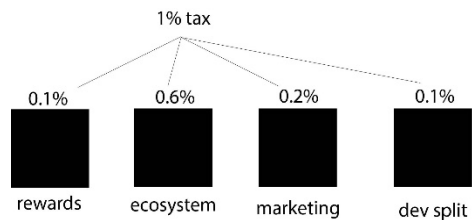

REWARDS after 1 month

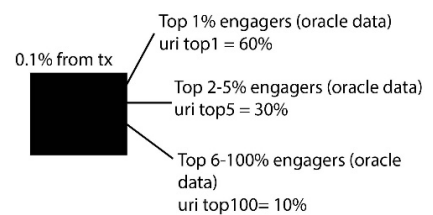

ALL GAS FEES WITHIN THE LITH ECOSYSTEM WILL BE PAYABLE VIA LITx. THIS IS MADE POSSIBLE WITH USAGE OF THE EIP-2612 AND WILL REDUCE GAS FEES OVERALL.

4.9.2 CARBON CREDIT NFTs

THE LITH ECOSYSTEM WILL INCLUDE A CARBON CREDIT MARKETPLACE WHICH WILL INCLUDE CARBON EMISSIONS DOCUMENTS STORED ON THE ESG BLOCKCHAIN HUB. THE CARBON CREDITS DOCUMENTS WILL BE SUPPLEMENTED WITH NFT ARTWORK WHICH PROVIDES AN ADDITIONAL INCENTIVE FOR BUSINESSES TO BE NET NEGATIVE WITH CARBON EMISSIONS. THEY WILL BE ABLE TO MINT AND EXCHANGE ONE OF A KIND NFT ARTWORK TO SUPPLEMENT

THEIR DOCUMENTS IN ORDER TO COLLECT PERPETUAL ROYALTIES SPLITS WITH ANY ARTISTS THEY USE FOR THE NFT ARTWORK. THIS ALSO ALLOWS PURCHASERS AN OPPORTUNITY TO RESELL THE NFT ARTWORK FOR A PROFIT, FURTHER INCENTIVIZING CARBON CREDIT PURCHASERS TO SUPPORT THE **LITH** ECOSYSTEM.

PROJECT DEVELOPMENT

5.1 STRATEGIC PARTNERSHIPS

THROUGH VARIOUS STRATEGIC PARTNERSHIPS, LITH AIMS TO CEMENT ITS POSITION AS THE LEADING ESG TOKEN.

SUSTAINABILITY IN THE EXTRACTION OF LITHIUM IS ONE OF THE MAIN PROBLEMS THAT IS HINDERING THE LITHIUM REVOLUTION. THIS IS CLEARLY SHOWCASED BY THE WAY THE INDIGENOUS PEOPLE'S LAND IN CHILE HAS BEEN JEOPARDIZED BY THE AGGRESSIVE MINING NEEDED FOR LITHIUM EXTRACTION. YOU CAN READ MORE ABOUT THIS ONGOING ISSUE AT THE GUARDIAN: THE RUSH TO 'GO ELECTRIC' COMES WITH A HIDDEN COST: DESTRUCTIVE LITHIUM MINING, REUTERS: INSIDE LITHIUM GIANT SQM'S STRUGGLE TO WIN OVER INDIGENOUS COMMUNITIES IN CHILE'S ATACAMA.

AS A COMMITMENT TO MAKING THE ENERGY TRANSITION A REALITY, THE **LITH TOKEN** TEAM HAS SECURED A PARTNERSHIP WITH ENSORCIA METALS, WHICH FOCUSES ON SUSTAINABLE EXTRACTION OF LITHIUM AND THE PRODUCTION OF HIGH PURITY BATTERY GRADE LITHIUM CARBONATE AND HYDROXIDE. THE EXTRACTION OF LITHIUM THROUGH THEIR UNIQUE TECHNOLOGY, WHICH PROVIDES SEVERAL BENEFITS COMPARED TO THE CONVENTIONAL EXTRACTION METHODS (SUSTAINABILITY, PORTABILITY AND REPEATABILITY TO NAME A FEW), WILL ALLOW MASS ADOPTION OF ELECTRIC ALTERNATIVES BY PROVIDING A BETTER AND MORE AFFORDABLE PRODUCTION METHOD FOR BATTERIES. **LITH** - IN COLLABORATION WITH ENSORCIA - HAS STARTED THE **INDIGENOUS PEOPLES INITIATIVE (IPI)**, FUNDING A WALLET WITH 10 MILLION **LITH** TOKENS. IN ADDITION, **LITH** WILL MATCH TOKEN FOR TOKEN EVERY CONTRIBUTION TO THIS CAUSE BY CURRENT HOLDERS, UP TO ANOTHER 10 MILLION **LITH**. READ MORE ABOUT THIS AT **LITH PARTNERSHIPS**.

ENSORCIA METALS IS THE FIRST OFFICIAL **LITH** PARTNER TO GET INVOLVED WITH THE **LITH** ECOSYSTEM. THEIR INVOLVEMENT HELPS INCREASE THE LIST OF PARTNERS THAT SHARE AN INTEREST IN MAKING LITHIUM TECHNOLOGY AND ELECTRIC ALTERNATIVES THE GOTO CHOICE FOR A MORE SUSTAINABLE FUTURE. THE **LITH** TEAM IS ALWAYS ON THE LOOKOUT FOR NEW PARTNERS AND COLLABORATORS. IF YOU'RE INTERESTED IN PARTNERING WITH **LITH** OR WOULD LIKE TO REQUEST MORE INFORMATION, PLEASE CONTACT US AT CONTACT@LITHTOKEN.IO. WE ARE HAPPY TO ANSWER ALL QUESTIONS!

5.2 ROADMAP

PHASE 1 - EARLY-STAGE PREP (JAN - APR 2021)

- PREPARE WHITEPAPER *(COMPLETED)*
- DEVELOP TOKEN INITIATIVE *(COMPLETED)*
- SECURE FIRST PARTNER *(COMPLETED)*
- TECHNOLOGY EXPLORATION *(COMPLETED)*

PHASE 2 - TOKEN LAUNCH (MAY - SEPT 2021)

- LAUNCH ERC-20 TOKEN FOR UNISWAP *(COMPLETED + PANCAKESWAP COMPLETED)*
- SECURE MARKETING PARTNERS *(COMPLETED)*
- EARLY ADOPTION CAMPAIGN *(ONGOING)*

PHASE 3 - TOKEN LAUNCH 2.0 (OCT - NOV 2021)

- LAUNCH ERC-1155 (LITHplus) ON **LITH HUB** *(COMPLETED)*
- LIST ON EXCHANGE *(1st CEX LISTED-- Wollito.com; COMPLETED)*
- SECURE LAYER 2 SOLUTION PARTNER *(UTILIZING OPTIMISM-- PROXY CONTRACT COMPLETED)*
- EXPAND I.T. & DEVELOPMENT TEAMS *(COMPLETED)*

PHASE 4 - MARKETPLACE & BLOCKCHAIN HUB (NOV 2021 - MAR 2022)

- OBTAIN FOUNDATION LICENSE *(ON SCHEDULE)*
- LAUNCH **LITH** MARKETPLACE ONLINE *(ON SCHEDULE)*
- INTEGRATE LAYER 2 SOLUTION *(COMPLETED)*
- SETUP ESG STANDARD SURVEY & REVIEW SYSTEMS *(ON SCHEDULE)*
- ADD TO THE DEVELOPMENT TEAM *(COMPLETED)*
- INTEGRATE CROSS CURRENCY PAYMENT SYSTEM *(PARTNER COMMITMENT SECURED)*
- CREATE **LITH** TOKEN NFT WALLET *(ON SCHEDULE)*

PHASE 5 - LITH ESG API & PLATFORM EXPANSION (APR - DEC 2022)

- BEGIN BLOCKCHAIN HUB API DEVELOPMENT *(ON SCHEDULE)*
- CREATE STANDARDIZED SUPPLY CHAIN DATABASE *(AHEAD OF SCHEDULE)*
- PARTNER API INTEGRATION TO BLOCKCHAIN HUB *(ON SCHEDULE)*
- OBTAIN LISTING ON THREE MAJOR EXCHANGES *(ON SCHEDULE)*
- BEGIN EXPANSION OF MARKETPLACE INTO SOCIAL MEDIA PLATFORM *(ON SCHEDULE)*

PHASE 6 - CEMENTING THE COMPLETE ECOSYSTEM (JAN 2023 +)

- LOBBY FOR LITH TO BECOME A CARBON TAX CREDIT (GLOBALLY) *(AHEAD OF SCHEDULE)*
- GAIN STRATEGIC PARTNERSHIPS WITH WORLD'S TOP ESG FOUNDATIONS *(AHEAD OF SCHEDULE)*
- SCALE UP SERVERS IN PARTNERSHIP WITH MAJOR ESG HOSTING PROVIDER *(AHEAD OF SCHEDULE)*

6.1 LITH TOKEN ISSUING TEAM

FOUNDER - ANDREW RYMER

6.2 DEVELOPMENT TEAM

BLOCKCHAIN ARCHITECT - ADAM D. ROORDA

PROJECT MANAGER - TALIA RANDAZZO

LEAD BLOCKCHAIN DEVELOPER - DMITRIY DOLININ

BLOCKCHAIN DEVELOPER - STEVE SCHAAF

SOFTWARE ENGINEER - ARTURO CHINCHILLA

LEAD PLATFORM DEVELOPER - JOHNNY DYER

JUNIOR PLATFORM DEVELOPERS - DYESCI, LLC

UX/ UI DEVELOPER - EVELYN GONZALEZ MALDONADO

PLATFORM DEVELOPERS - QUADRABYTE, LLC

DEVICE PROGRAMMING ENGINEERS - TAP2INTERACT, LLC

6.3 MARKETPLACE MANAGEMENT TEAM

BUSINESS DEVELOPMENT - PETER CHEATHAM

DIRECTOR OF ADMINISTRATION - TANYA ROCHELLE RAGSDALE

6.4 MARKETING & PUBLIC RELATIONS

MARKETING ADVISOR - BLAINE LAFLEUR

COMMUNITY & SOCIAL OPERATIONS - LAUREN MARPLE

DIRECTOR OF INFLUENCER & BRAND RELATIONSHIPS - BROOKLYN BARWICK

BUSINESS RELATIONS CONSULTANT - ROBERT SCOTT

*****CONTACT EMAILS ARE THE FIRSTNAME@LITHTOKEN.IO**

6.5 LEGAL DISCLAIMER

LITH TOKEN AND THIS WHITE PAPER DOES NOT CONSTITUTE A PROSPECTUS OR OFFER DOCUMENT OF ANY SORT AND IS NOT INTENDED TO CONSTITUTE AN OFFER OF SECURITIES OF A SOLICITATION FOR INVESTMENT IN SECURITIES IN ANY JURISDICTION. THIS WHITE PAPER IS BEING PUBLISHED SOLELY TO RECEIVE FEEDBACK AND COMMENTS FROM THE PUBLIC. IF/WHEN LITH TOKEN OFFERS FOR SALE ANY TOKENS AS SECURITIES, IT WILL DO SO THROUGH DEFINITIVE OFFERING DOCUMENTS, INCLUDING A DISCLOSURE DOCUMENT AND RISK FACTORS. THOSE DEFINITIVE DOCUMENTS ALSO ARE EXPECTED TO INCLUDE AN UPDATED VERSION OF THIS WHITE PAPER, WHICH MAY DIFFER SIGNIFICANTLY FROM THE CURRENT VERSION. IF/WHEN LITH TOKEN MAKES SUCH AN OFFERING IN THE UNITED STATES, THE OFFERING LIKELY WILL BE AVAILABLE SOLELY TO ACCREDITED INVESTORS.

THE INFORMATION SHARED IN THIS WHITE PAPER IS NOT ALL-ENCOMPASSING OR COMPREHENSIVE AND DOES NOT IN ANY WAY INTEND TO CREATE OR PUT INTO IMPLICIT EFFECT ANY ELEMENTS OF A CONTRACTUAL RELATIONSHIP. THE PRIMARY PURPOSE OF THIS WHITE PAPER IS TO PROVIDE POTENTIAL TOKEN HOLDERS WITH PERTINENT INFORMATION FOR THEM TO THOROUGHLY ANALYZE THE PROJECT AND MAKE AN INFORMED DECISION. LITH TOKEN DOES NOT MAKE OR PURPORT TO MAKE, AND HEREBY DISCLAIMS, ANY REPRESENTATION, WARRANTY OR UNDERTAKING IN ANY FORM WHATSOEVER TO ANY ENTITY OR PERSON, INCLUDING ANY REPRESENTATION, WARRANTY OR UNDERTAKING IN RELATION TO THE ACCURACY AND COMPLETENESS OF ANY OF THE INFORMATION SET OUT IN THIS WHITE PAPER.

WE STRONGLY ADVOCATE A CAREFUL STUDY OF THIS WHITE PAPER, INCLUDING ALL THE DOCUMENTS ASSOCIATED WITH THE SAME. NO INFORMATION IN THIS WHITE PAPER SHOULD BE CONSIDERED BUSINESS, LEGAL, FINANCIAL OR TAX ADVICE REGARDING LITH TOKEN. PLEASE CONSULT YOUR OWN LEGAL, FINANCIAL, TAX OR OTHER PROFESSIONAL ADVISOR REGARDING LITH TOKEN AND THIS WHITE PAPER.

CERTAIN STATEMENTS, ESTIMATES AND FINANCIAL INFORMATION FEATURED IN THIS WHITE PAPER OR ANY OTHER PLACE ACCESSIBLE BY THE PUBLIC AND ORAL STATEMENTS THAT MAY BE MADE BY LITH TOKEN OR ITS RESPECTIVE DIRECTORS, EXECUTIVE OFFICERS OR EMPLOYEES ACTING ON BEHALF OF LITH TOKEN ARE FORWARD-LOOKING STATEMENTS THAT ARE BASED ON AND TAKE INTO CONSIDERATION CERTAIN KNOWN AND UNKNOWN CONTINGENCIES AND RISKS WHICH IN EVENTUALITY MAY CAUSE THE ESTIMATED RESULTS OR MAY DIFFER FACTUALLY AND SUBSTANTIALLY FROM THE FEATURED ESTIMATES OR RESULTS EXTRAPOLATED OR EXPRESSED IN SUCH FORWARD-LOOKING STATEMENTS HERewith. SOME OF THESE STATEMENTS CAN BE IDENTIFIED BY FORWARD-LOOKING TERMS SUCH AS “AIM”, “TARGET”, “ANTICIPATE”, “BELIEVE”, “COULD”, “ESTIMATE”, “EXPECT”, “IF”, “INTEND”, “MAY”, “PLAN”, “POSSIBLE”, “PROBABLE”, “PROJECT”, “SHOULD”, “WOULD”, “WILL” OR OTHER SIMILAR TERMS. NEITHER LITH TOKEN NOR ANY OTHER PERSON REPRESENTS, WARRANTS AND/OR UNDERTAKES THAT THE ACTUAL FUTURE RESULTS, PERFORMANCE OR ACHIEVEMENTS OF LITH TOKEN WILL BE AS DISCUSSED IN THOSE FORWARD-LOOKING STATEMENTS. THE ACTUAL RESULTS, PERFORMANCE OR ACHIEVEMENTS OF LITH TOKEN MAY DIFFER MATERIALLY FROM THOSE ANTICIPATED IN THESE FORWARD-LOOKING STATEMENTS.

NOTHING IN THIS WHITE PAPER SHOULD BE TREATED OR READ AS AS GUARANTEE OR PROMISE OF HOW LITH TOKEN’S BUSINESS OR THE TOKENS WILL DEVELOP OR OF THE UTILITY OR VALUE OF THE TOKENS. THIS WHITE PAPER OUTLINES CURRENT PLANS, WHICH COULD CHANGE AT ITS SOLE DISCRETION, AND THE SUCCESS OF WHICH WILL DEPEND ON MANY FACTORS OUTSIDE LITH’S CONTROL, INCLUDING MARKET-BASED FACTORS AND FACTORS WITHIN THE DATA AND CRYPTOCURRENCY INDUSTRIES, AMONG OTHERS. ANY STATEMENTS ABOUT FUTURE EVENTS ARE BASED SOLELY ON LITH’S ANALYSIS OF THE ISSUES DESCRIBED IN THIS WHITE PAPER. THAT ANALYSIS MAY PROVE TO BE INCORRECT.

LITH TOKEN DOES NOT RECOMMEND PURCHASING LITH TOKENS FOR SPECULATIVE INVESTMENT PURPOSES. LITH TOKENS DO NOT ENTITLE YOU TO ANY EQUITY, GOVERNANCE, VOTING OR SIMILAR RIGHT OR ENTITLEMENT IN THE BUSINESS OR IN ANY OF ITS AFFILIATED COMPANIES. LITH TOKENS ARE SOLD AS DIGITAL ASSETS, SIMILAR TO DOWNLOADABLE SOFTWARE, DIGITAL MUSIC AND THE LIKE. WE DO NOT RECOMMEND THAT YOU PURCHASE LITH TOKENS UNLESS YOU HAVE PRIOR EXPERIENCE WITH CRYPTOGRAPHIC TOKENS, BLOCKCHAIN-BASED SOFTWARE AND DISTRIBUTED LEDGER TECHNOLOGY AND UNLESS YOU HAVE TAKEN INDEPENDENT PROFESSIONAL ADVICE.

FOR THE AVOIDANCE OF DOUBT, IN NO EVENT SHALL LITH AND/OR ITS ADVISORS BE LIABLE FOR ANY DAMAGES, WHETHER DIRECT, INDIRECT, SPECIAL, INCIDENTAL OR CONSEQUENTIAL, ARISING FROM THE USE, REFERENCE OR RELIANCE ON THE CONTENTS OF THIS WHITE PAPER OR ANY OPINION OR INFORMATION EXPRESSLY OR IMPLICITLY CONTAINED IN THIS WHITE PAPER.

LEGAL CONTACT:

**OVERSTREET HOMAR & KUKER
508 E. 18TH STREET
CHEYENNE, WYOMING 82001**

PHONE: +1 307-274-4444

FASCIMILE: +1 307-274-4443